

Specifications of PE Module(STERAPORE™ 5000 Series)

[Table of Specifications]

Model No.	Element Model No.	Number of Elements (pcs)	Membrane Surface Area (m ²)	Diffuser Type	Dry Weight (kg)	Minimum water depth (m)
50M0105LP	50E0002SL	70	105	PVC pipe	205	1.9
50M0105LS				Rubber slit	210	1.9
50M0105LN				—	165	—
50M0210LP	50E0003SL	70	210	PVC pipe	210	1.9
50M0210LS				Rubber slit	215	1.9
50M0210LN				—	170	—

Product specifications and shape described herein are subject to change without notice.

< Reference drawing ① >

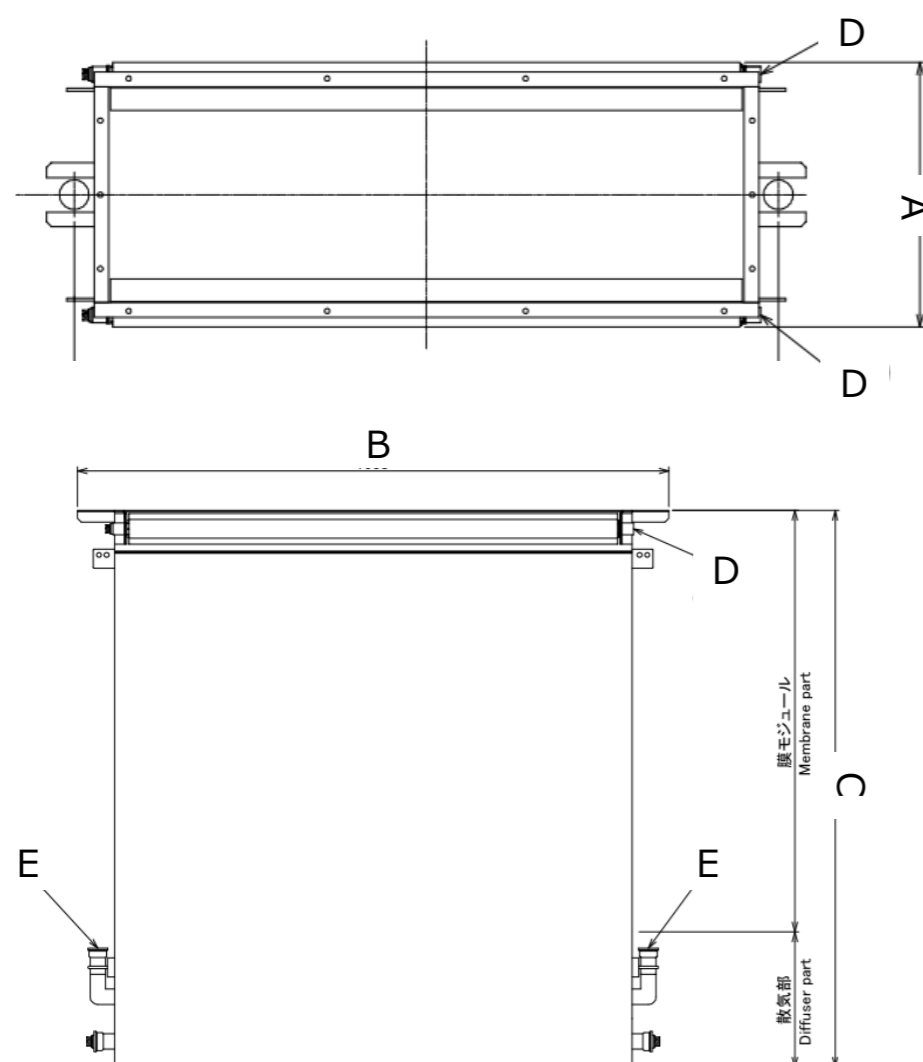

[Table of Dimensions]

Model No.	Element Model No.	Dimensions (mm)			Connection		Reference drawing
		Depth	Width	Height	Permeate Nozzle	Air Nozzle	
		A	B	C	D	E	
50M0105LP	50E0002SL	540	1540	1,450	Rc 3/4	Rp1	①
50M0105LS		680	1,540	1,450	Rc 3/4	R1 1/2	②
50M0105LN		540	1,540	1,100	Rc 3/4	—	—*
50M0210LP	50E0003SL	620	1,540	1,450	Rc 3/4	Rp1	①
50M0210LS		730	1,540	1,450	Rc 3/4	R1 1/2	②
50M0210LN		620	1,540	1,100	Rc 3/4	—	—*

* : Please contact us for more information.

< Reference drawing ② >

