

---

Presentation for  
**Analyst Meeting**

November 21, 2006

Ryuichi Tomizawa  
President & CEO  
Mitsubishi Chemical Holdings Corporation

---

# Agenda

---

- Interim Financial Results for the Year Ending March 31, 2007
- Management Challenge in the MCHC\* Group
- Performance & Functional Products Segment
  - ✚ Future Perspectives
  - ✚ Mitsubishi Polyester Film Group
  - ✚ Mitsubishi Chemical Functional Products, Inc.

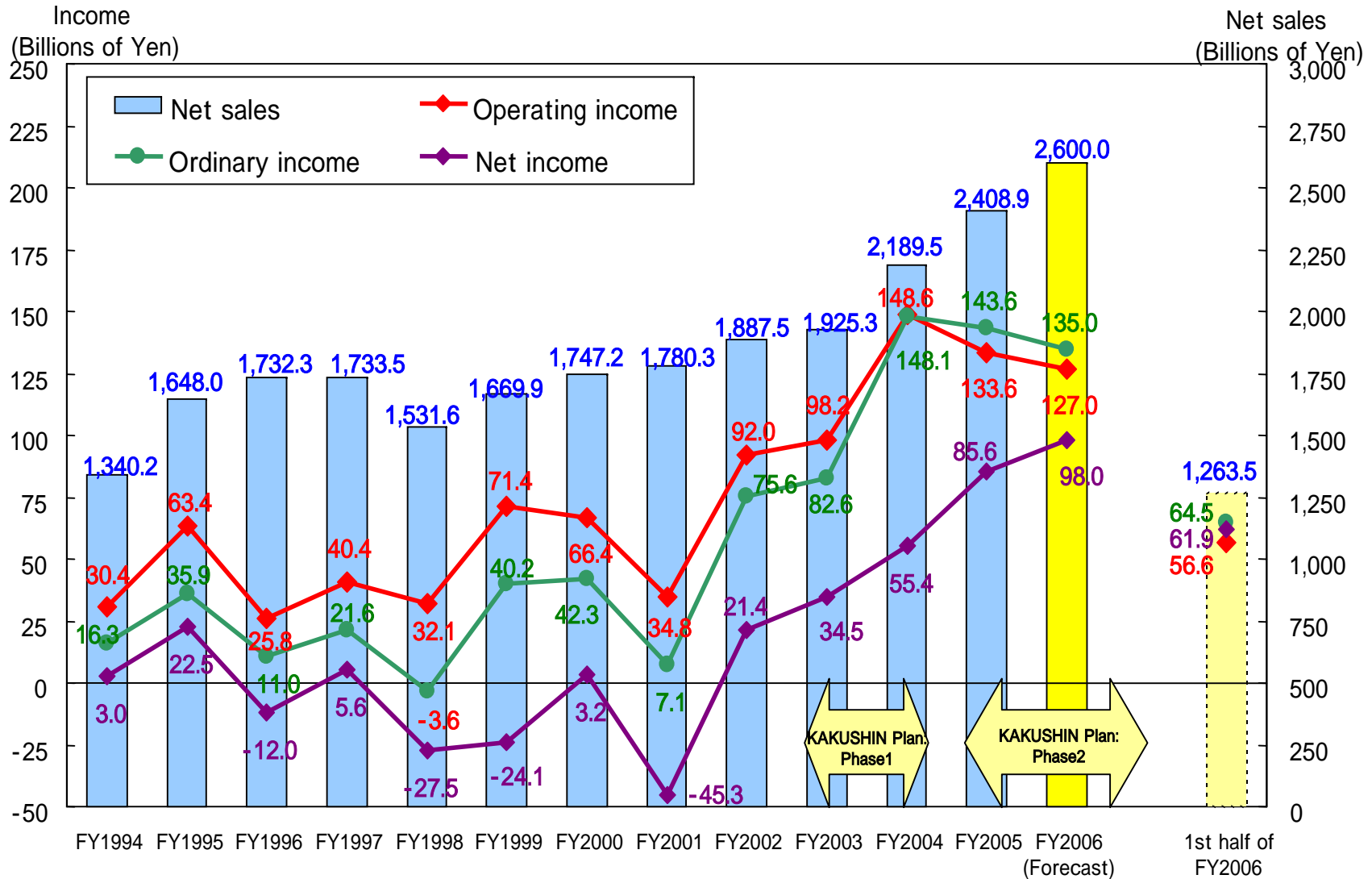

\* Mitsubishi Chemical Holdings Corporation

# Historical Summary



# Agenda

---

- Interim Financial Results for the Year Ending March 31, 2007
- Management Challenge in the MCHC\* Group
- Performance & Functional Products Segment
  -  Future Perspectives
  -  Mitsubishi Polyester Film Group
  -  Mitsubishi Chemical Functional Products, Inc.

\* Mitsubishi Chemical Holdings Corporation

## Management Challenge in the MCHC Group

- Manage against cyclical and naphtha price fluctuations
- Sustain attractive new product/business pipelines

- Measures on diversified sources of feedstocks; collaboration w/ oil refineries
- Changes in business model
- Business expansion & resource allocation on concentration businesses

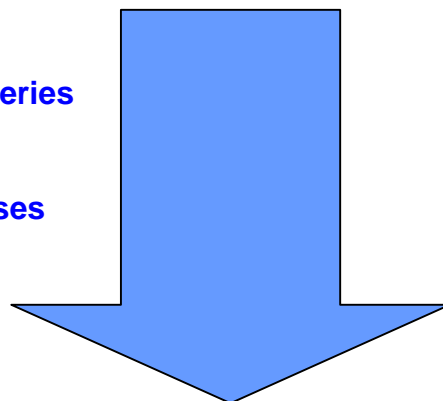

- Businesses in performance & functional products and health care have increased strength to raise the level of profit.
- Further portfolio restructuring and strengthening of businesses are in progress.

# Contribution from Performance and Functional Products and Health Care

Operating income  
(Billions of Yen)

Contribution from Performance and Functional Products and Health Care have reached at the level of ¥100 billion (operating income).

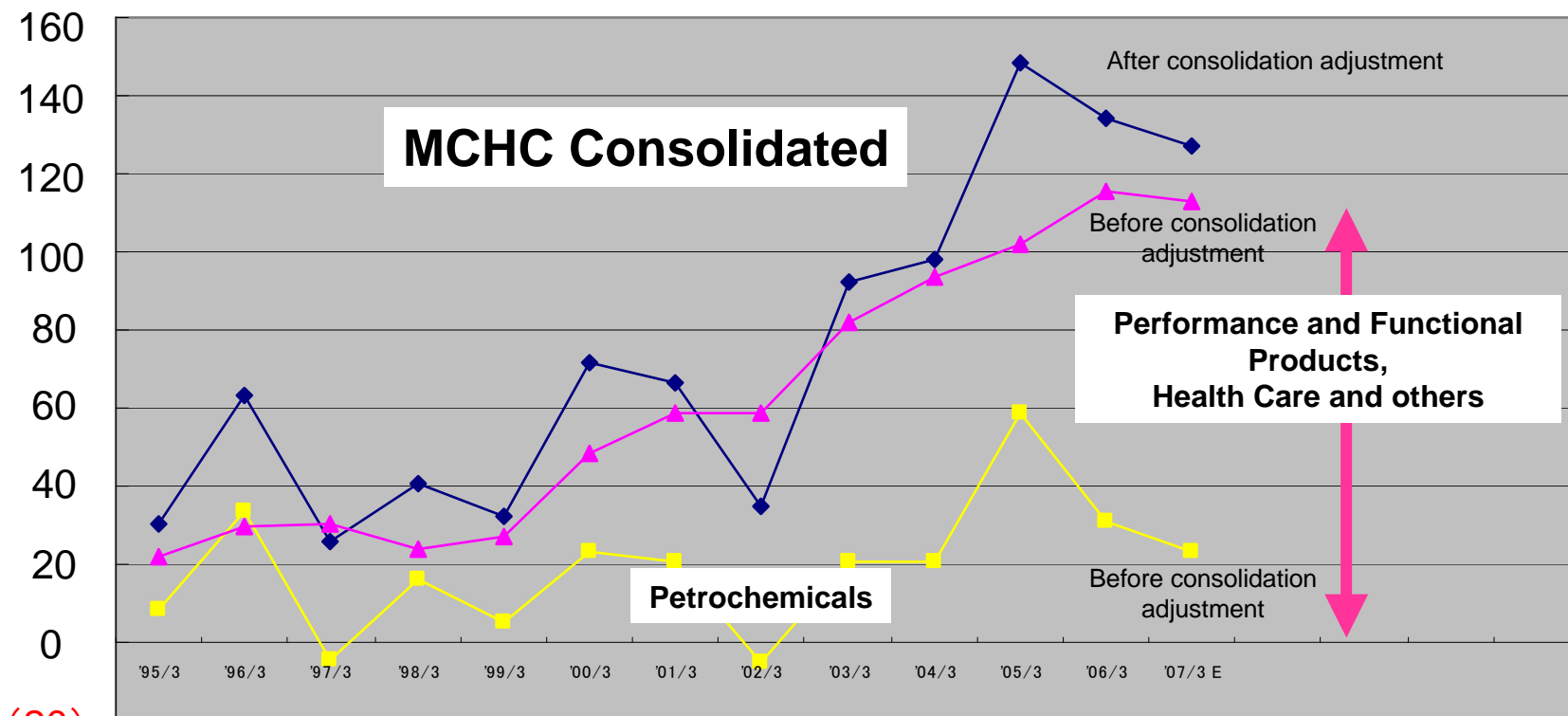

(20)

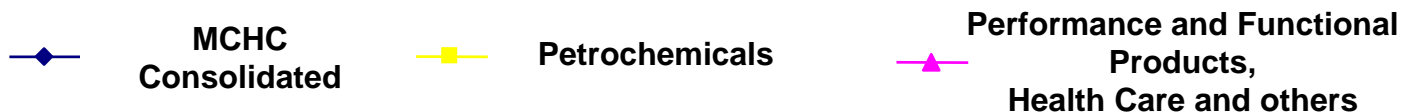

## Net Sales & Operating Income by Segments

**Profit Drivers:**  
**Performance and Functional Products & Health Care**

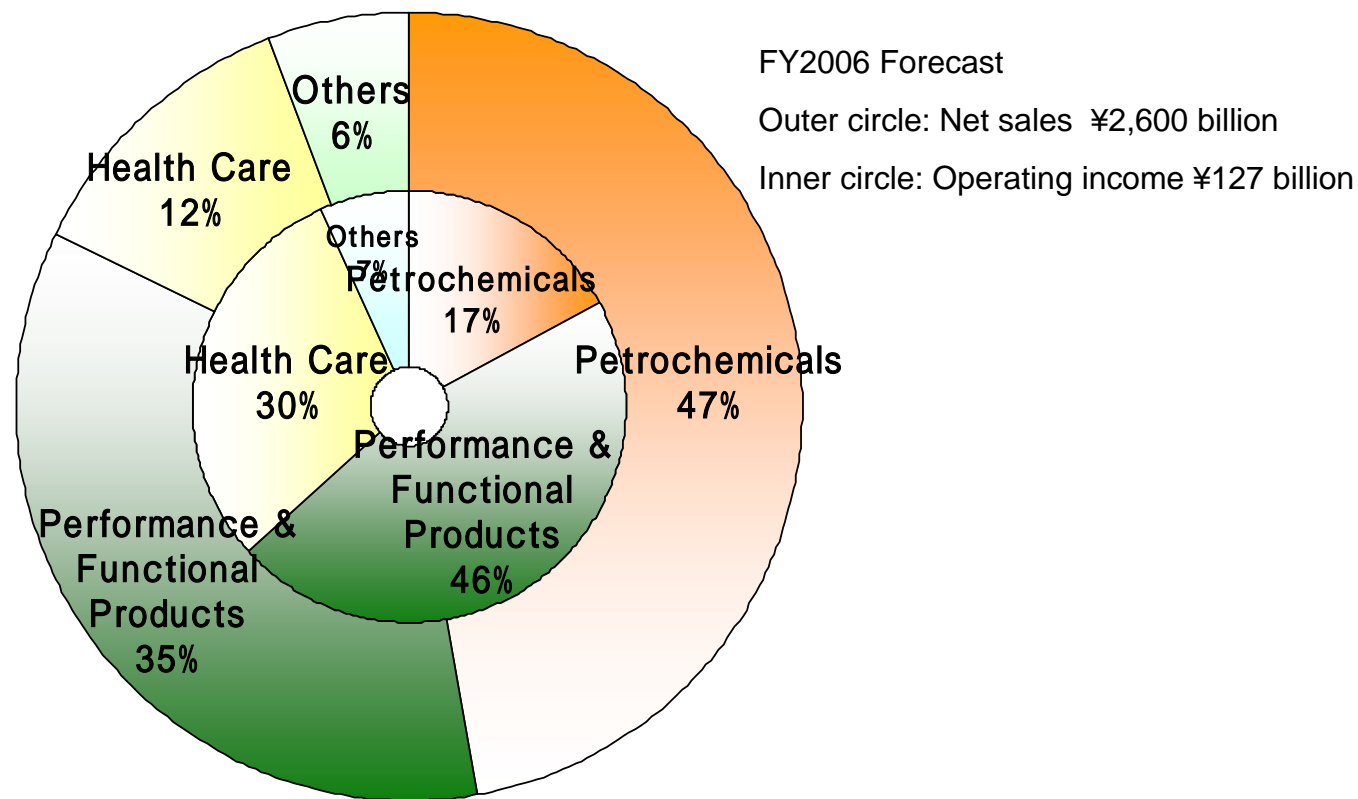

## Toward Strengthening High-Value-Added Business

### Thorough dialogue with customers

- **Much faster:** Identify changes in business environments (values) and suggest solutions to customers ahead of others.
- **Much wider:** Integrate technologies and know-how and pursue business models
- **More passionate:** Improve customers' commercial values by high-quality solution



Customer  
Laboratory

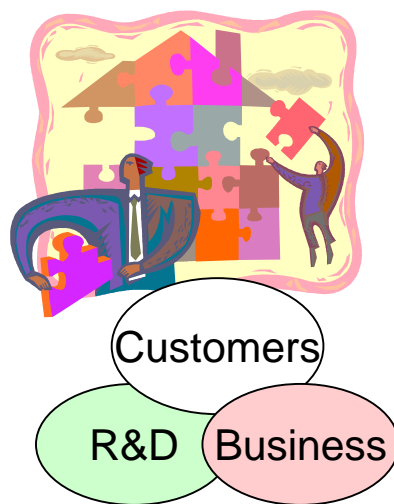

Chemistry  
Plaza





# Response to Changes in Business Environment (Value)

**Society**

Accelerated changes in value recognition for environment & health

**Customers**

Bigger impact and faster changes required from society

**Speed!**

**MCHC Group**

Early collaboration and fast action are indispensable

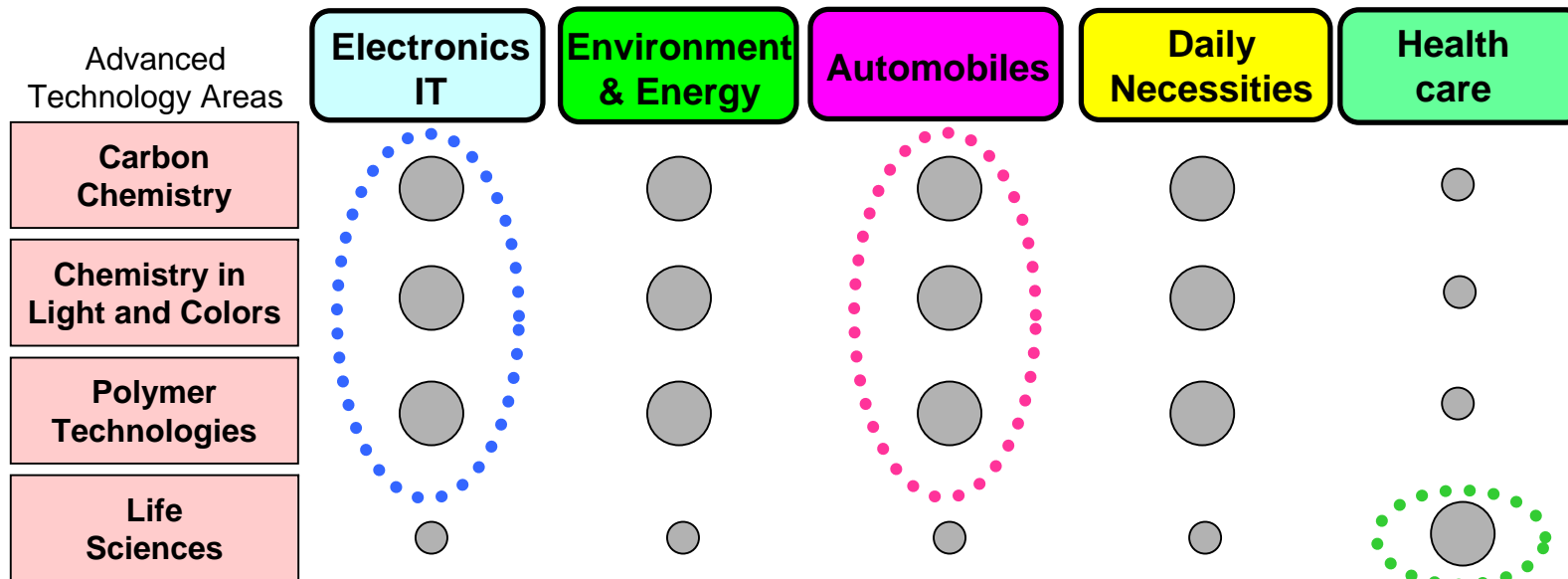

 : Business areas where “early stage collaboration” and/or “quick actions” are required.

# Agenda

---

- Interim Financial Results for the Year Ending March 31, 2007
- Management Challenge in the MCHC\* Group
- Performance & Functional Products Segment
  - ✚ Future Perspectives
  - ✚ Mitsubishi Polyester Film Group
  - ✚ Mitsubishi Chemical Functional Products, Inc.

\* Mitsubishi Chemical Holdings Corporation

# Historical Summary and Business Structure for the Performance & Functional Products Segment

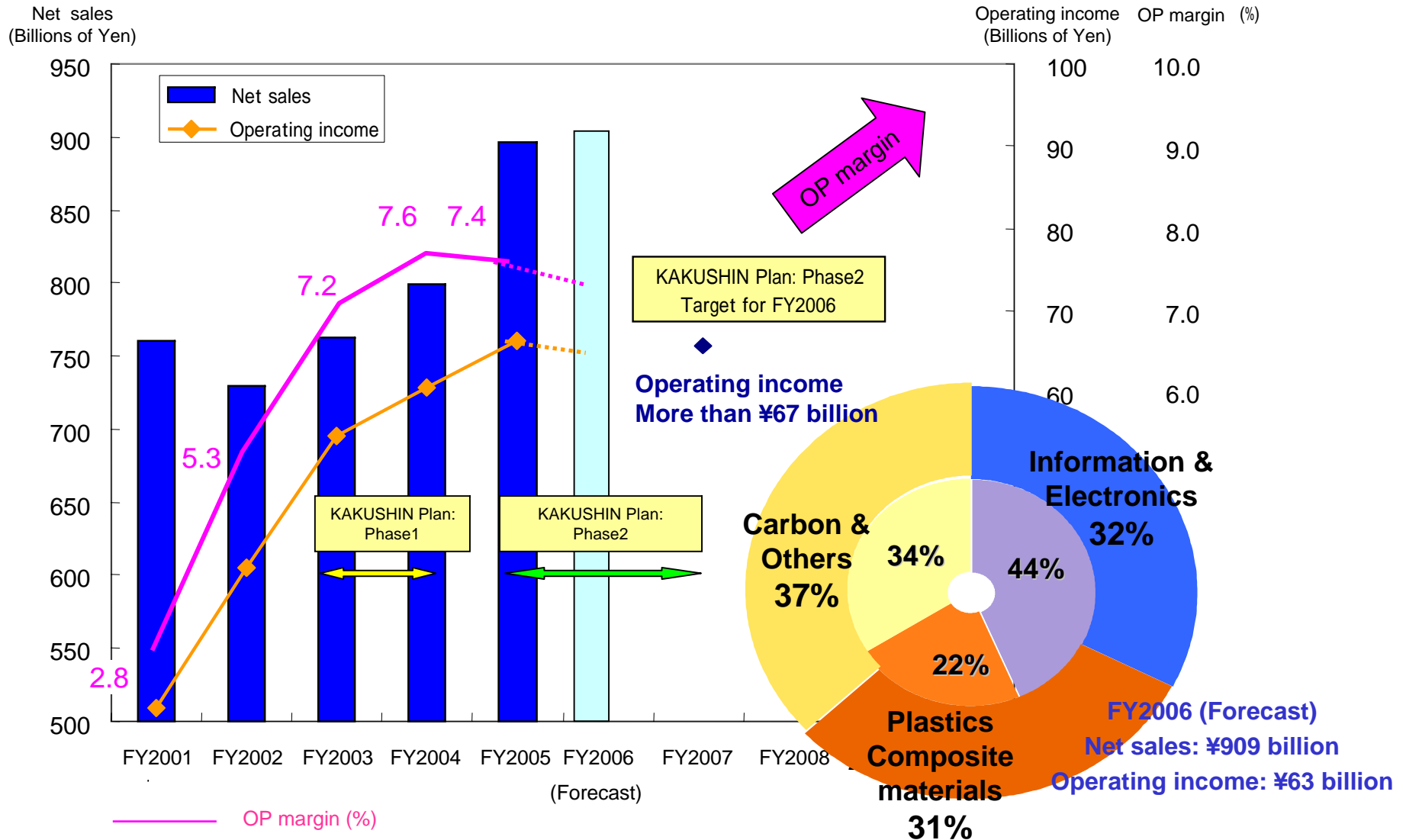

# Information and Electronics Related Business

**Performance & Functional Products Segment**

**Information & Electronics Related Business (Net sales)**

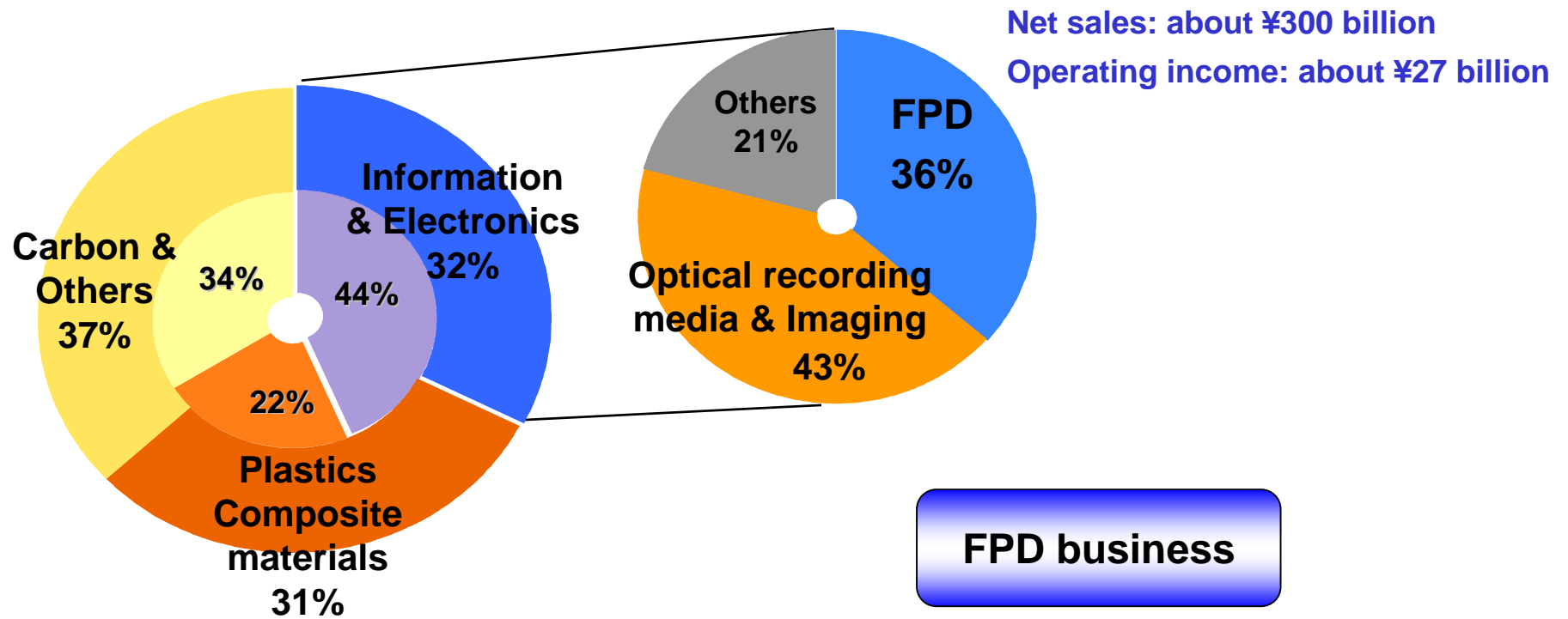

**FY2006 (Forecast)**  
 Net sales: ¥ 909 billion  
 Operating income: ¥63 billion

**Type 1: Component business**  
**Type 2: Process related materials**

# “LCD Components” Supported by Wide-ranging Technologies

## Structure of LCD panel

## LCD Component Businesses in the MCHC Group

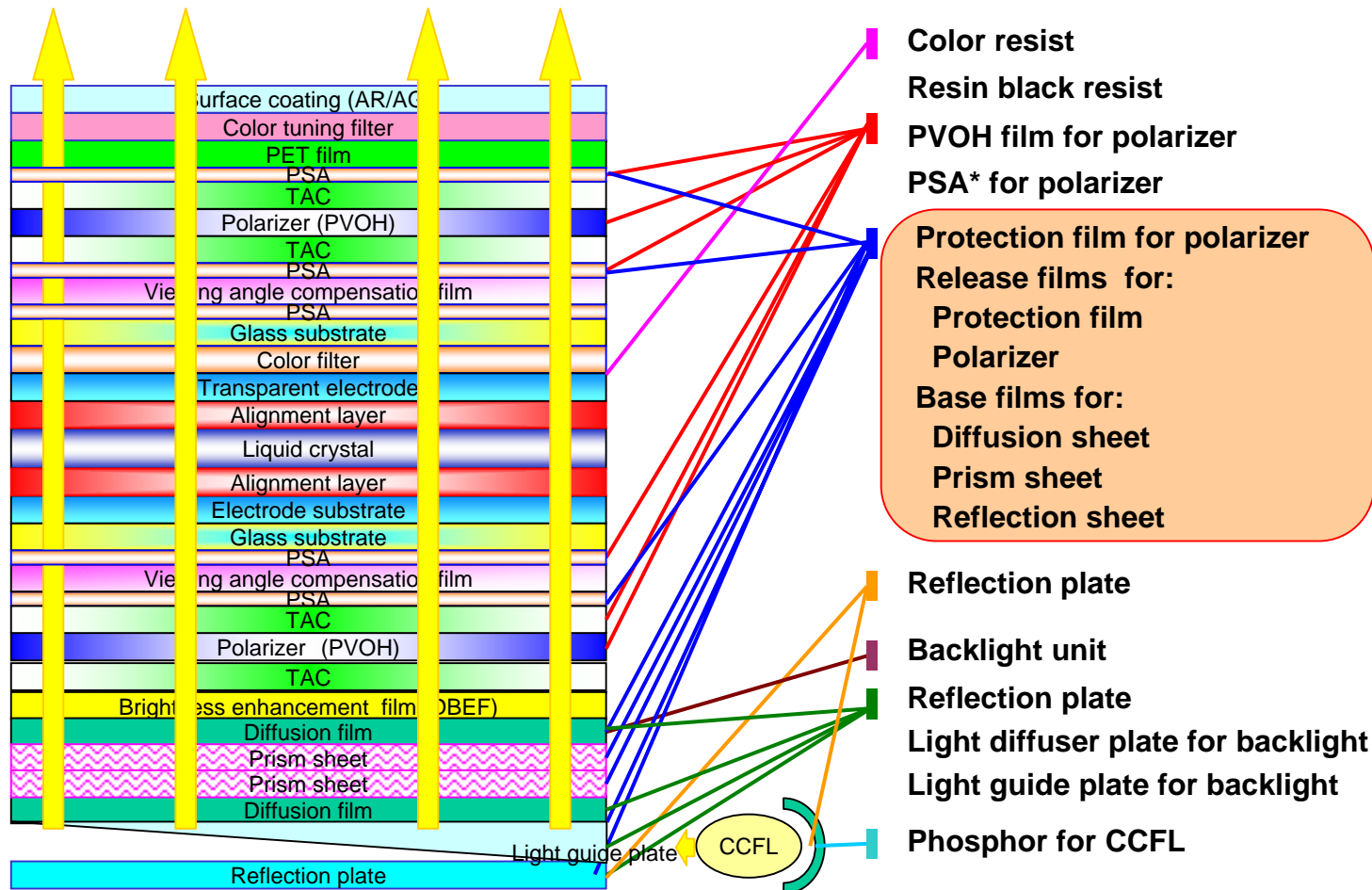

Mitsubishi Polyester Film Group

\*Pressure Sensitive Adhesion

# Unique Technologies for LCD Production Lines

## Businesses related to LCD manufacturing in the MCHC Group

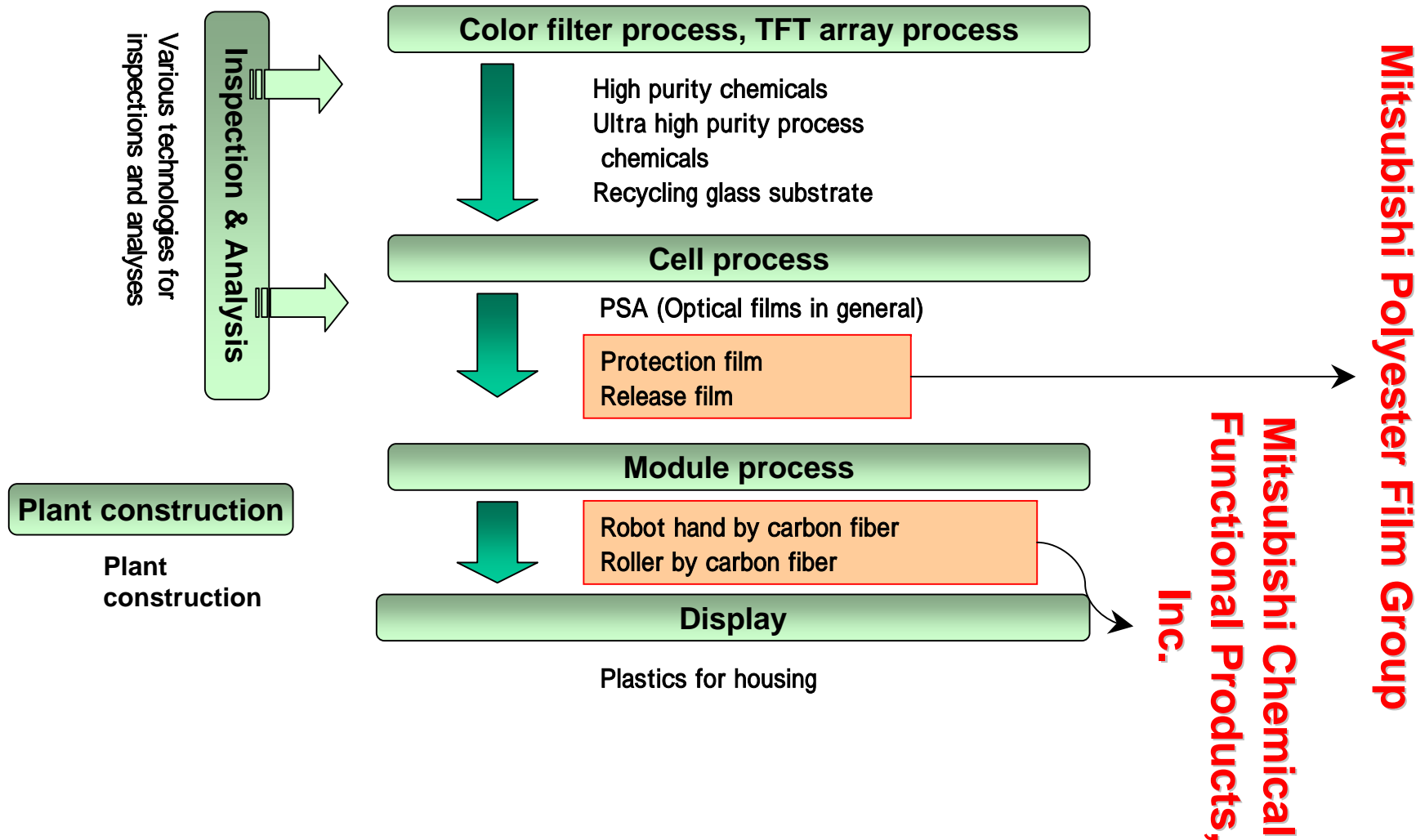

# Toward High-Value-Added Product Businesses

Business development maximizing new product incubation and solution capabilities

e.g. Approach to the market for FPD related materials and components

(Trillions of Yen)

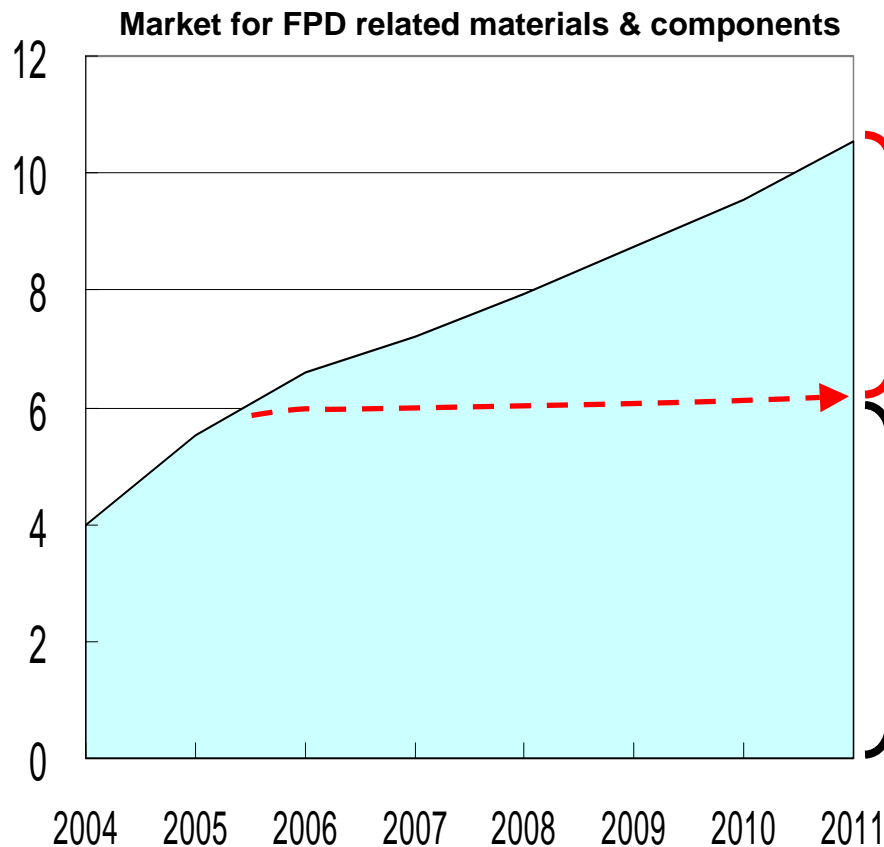

**: Targets**

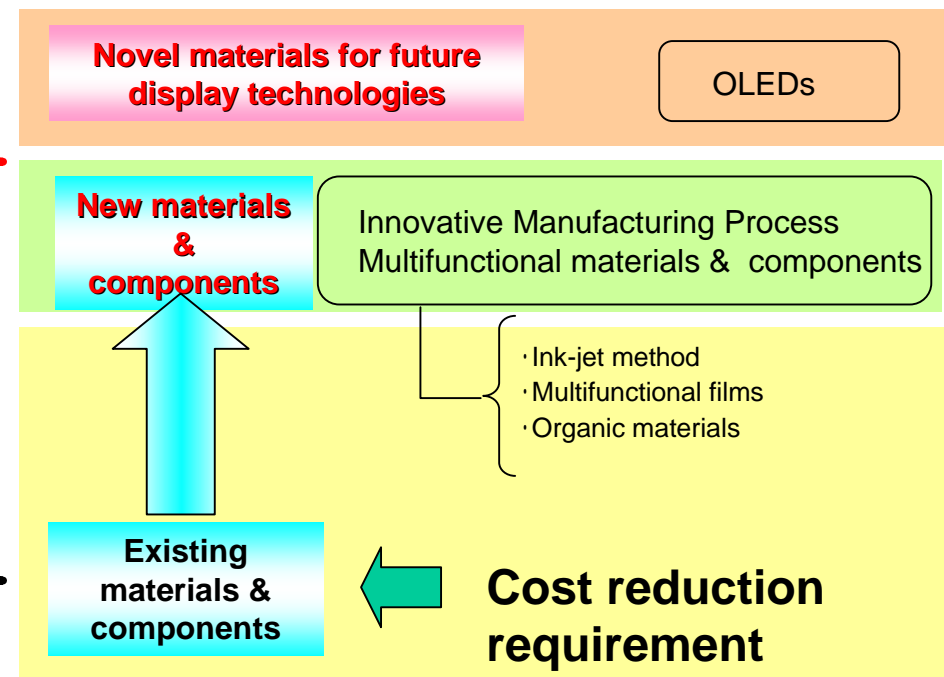

Source: Fuji Chimera Research Institute, Inc.

# New Business Development Technology Platform

**R&D ¥100 billion/3 years**

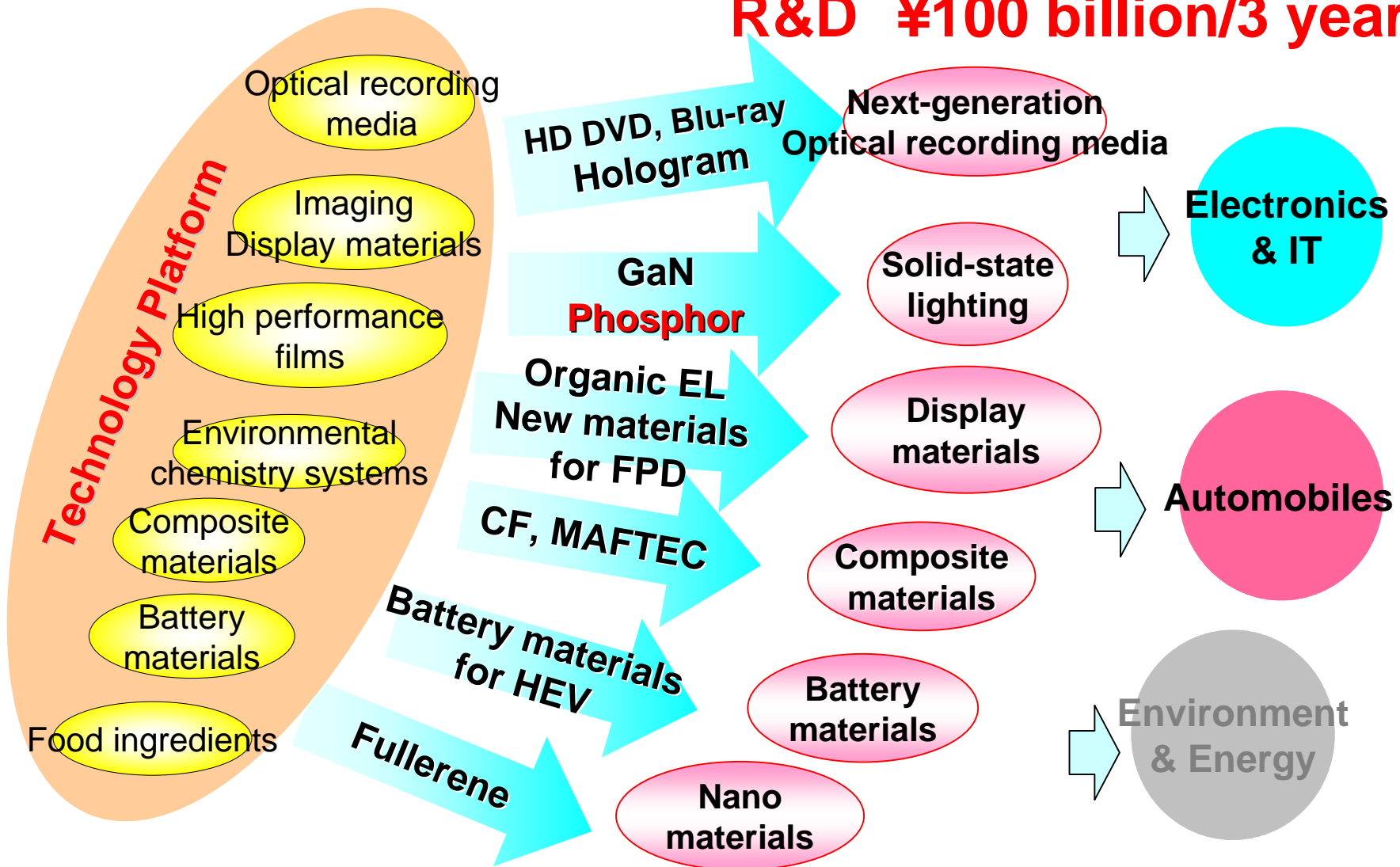



## Aiming at a Global Leading Runner with Customers

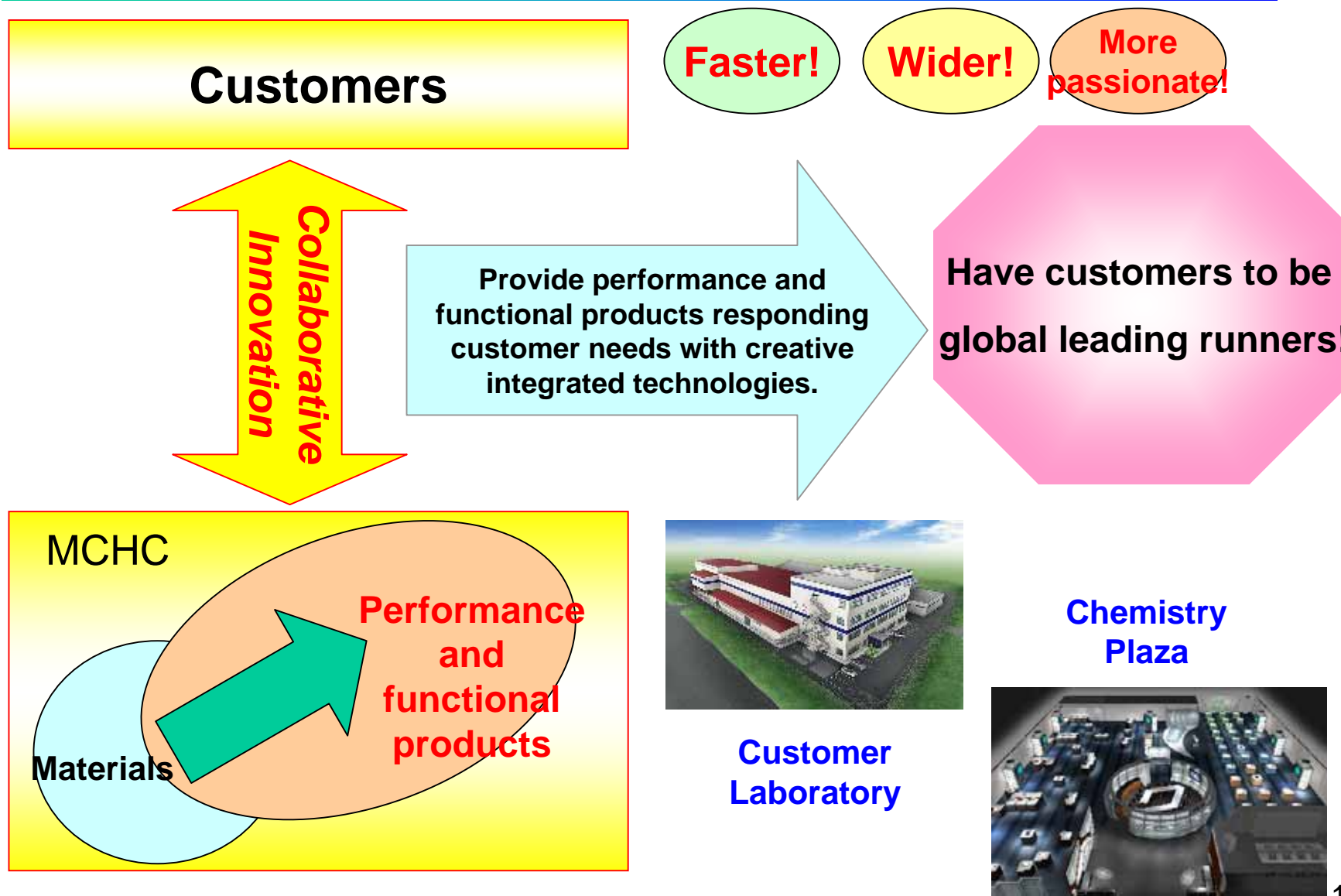

*Good **Chemistry** for Tomorrow*

Creating better relationships among people, society, and our planet.

# Mitsubishi Polyester Film Group



**November 21, 2006**

**Steve Yurich, CEO**

1. Mitsubishi Polyester Film Group  
at a Glance
2. Today's Message
3. Business Topics
  - Market Valuation
  - Release Film, FPD\*
  - New Application Opportunities
4. Summary

\*Flat Panel Display

# History of Mitsubishi Polyester Film

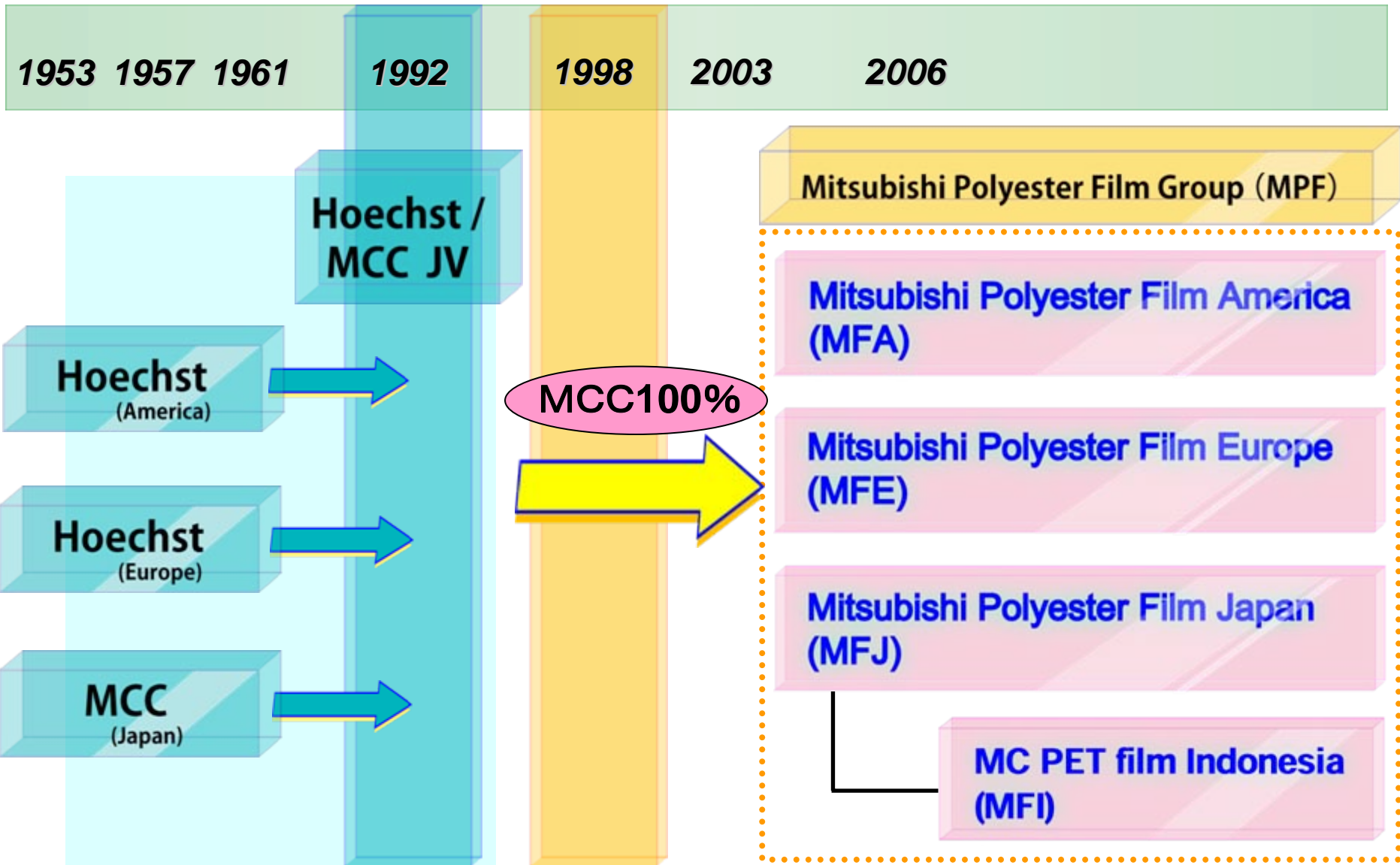

# Location

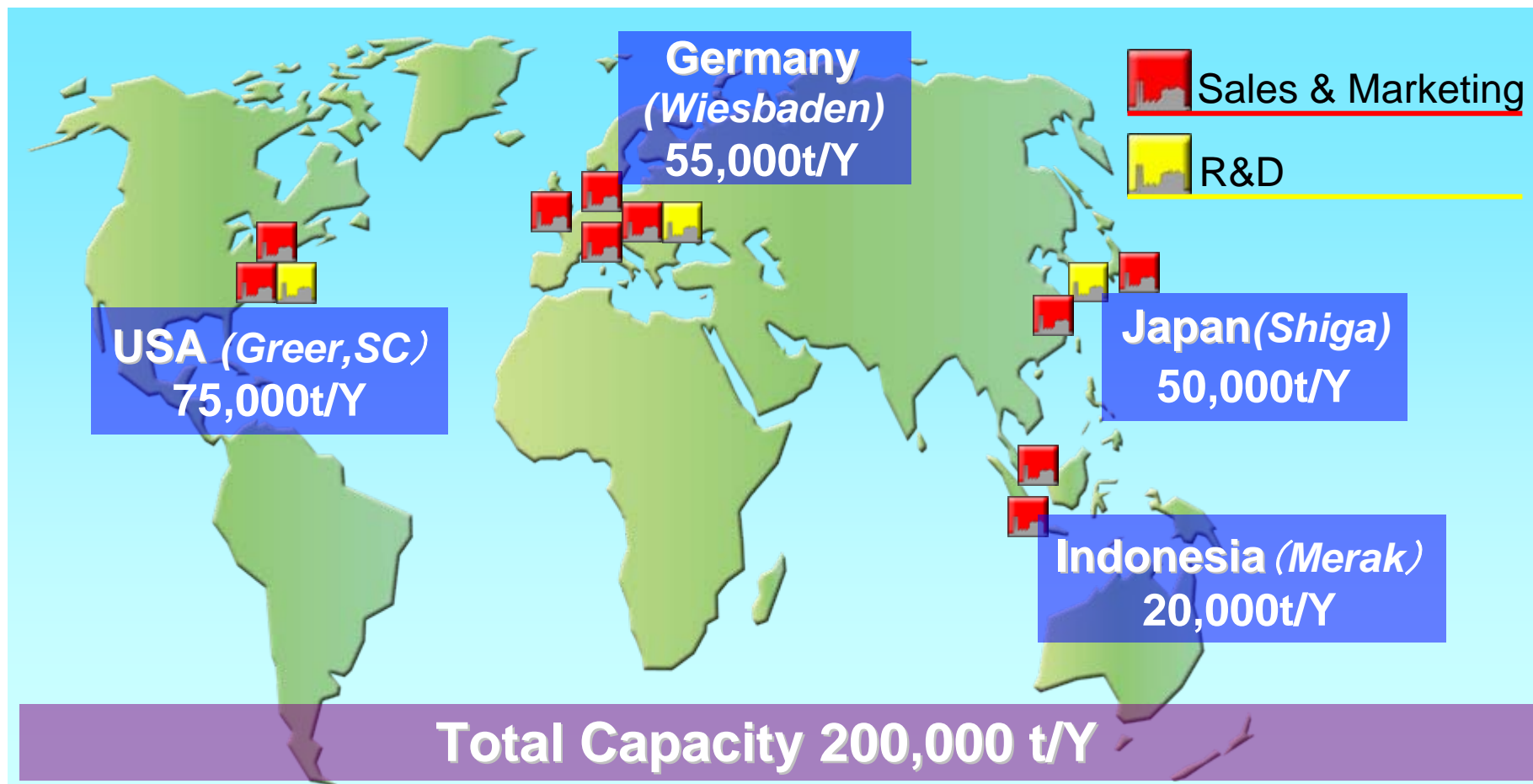

## Mitsubishi Polyester Film Group

- One of the leading companies in PET film business worldwide
- Located in USA, Germany, Japan, and Indonesia

# Brief History of Steve Yurich

My career has encompassed many **functions** and **business units** and three parent **companies**, American, German and Japanese.





# Vision, Slogan, Policy



## Vision

**MPF will be the global leader in polyester film.**

**We will be recognized as a 'solution company' focused on creating and capturing value in partnership with our customers.**

**We will maximize synergies and profitability across all business functions and regions and will consistently meet or exceed our stakeholders' expectations.**



## Slogan

**WORLD CLASS**



## Policy

**Maximize our profit by focus on key growth specialty market where MPF has an No.1 or No.2 position in products and technology.**

**Focus includes customer collaboration in product development, technology platform development, global expansion of product line, and human capital positioning.**



## Revenue

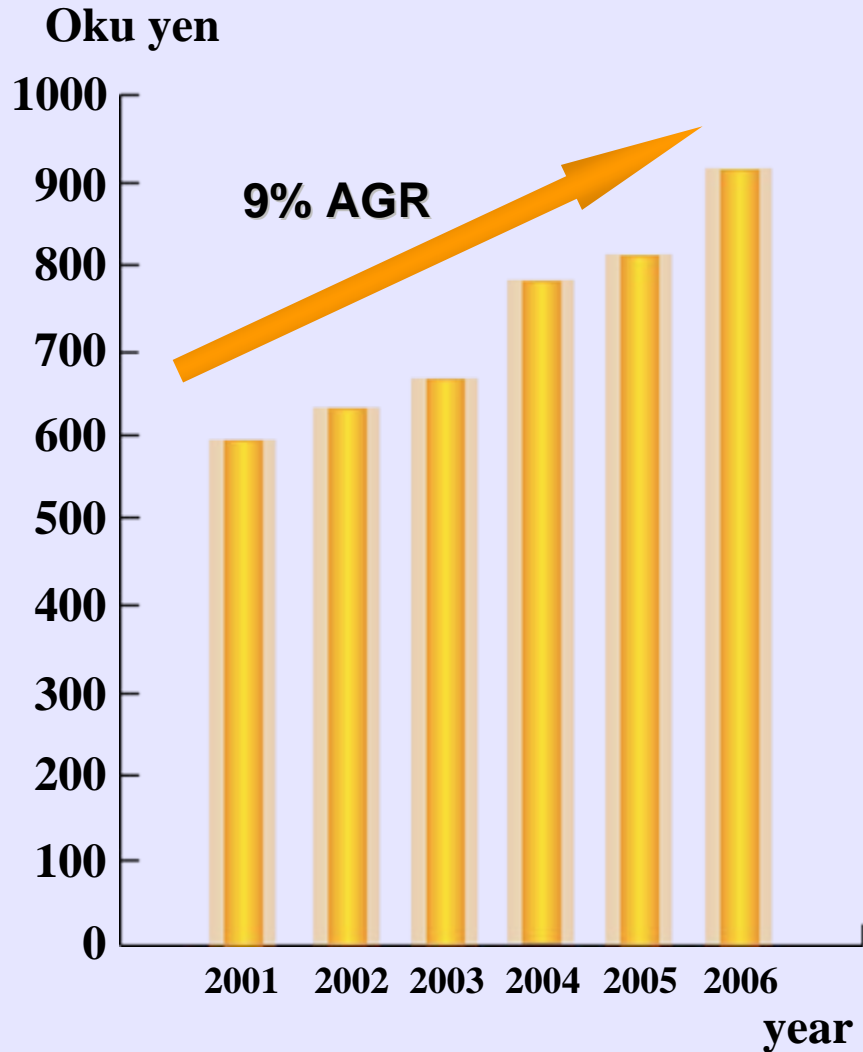

## Revenue by Regions

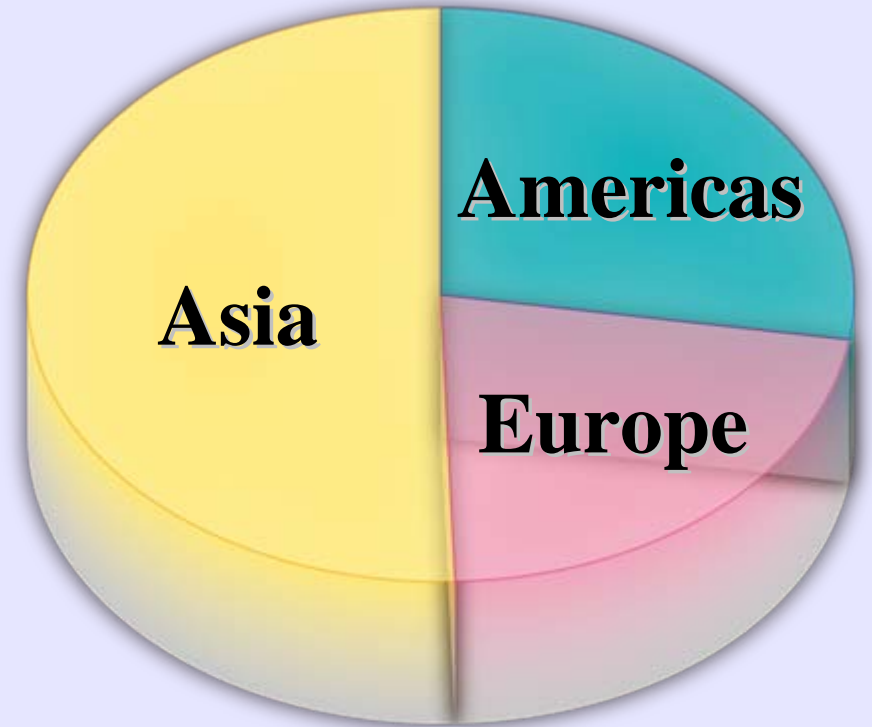

# Today's Message

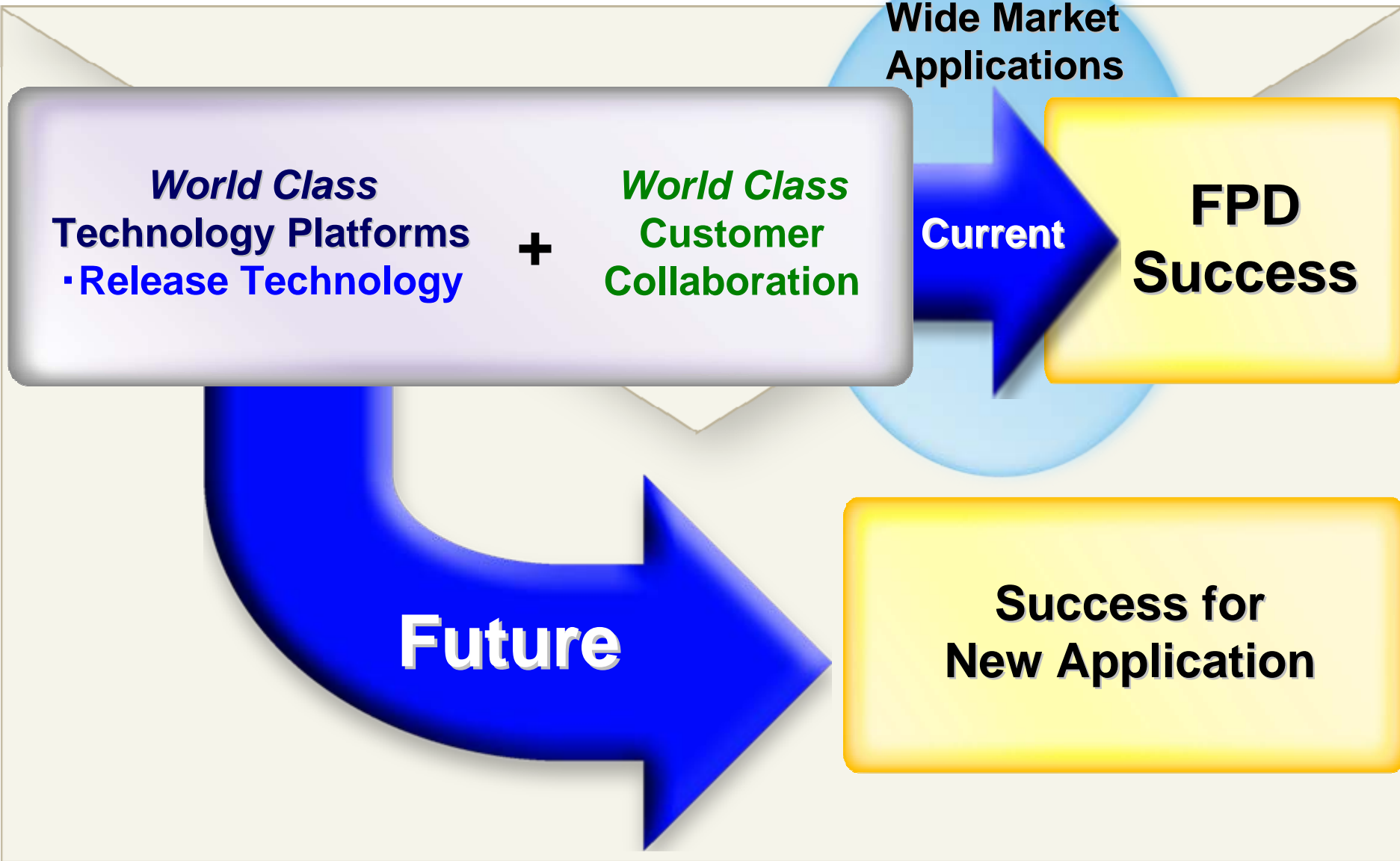

Wide Market Applications

*World Class*  
Technology Platforms  
• Release Technology

+

*World Class*  
Customer  
Collaboration

Current

**FPD  
Success**

Future

**Success for  
New Application**

# Current Application Examples

Brand name : Diafoil®, Hostaphan®, Fusion®



# Market Valuation of existing products

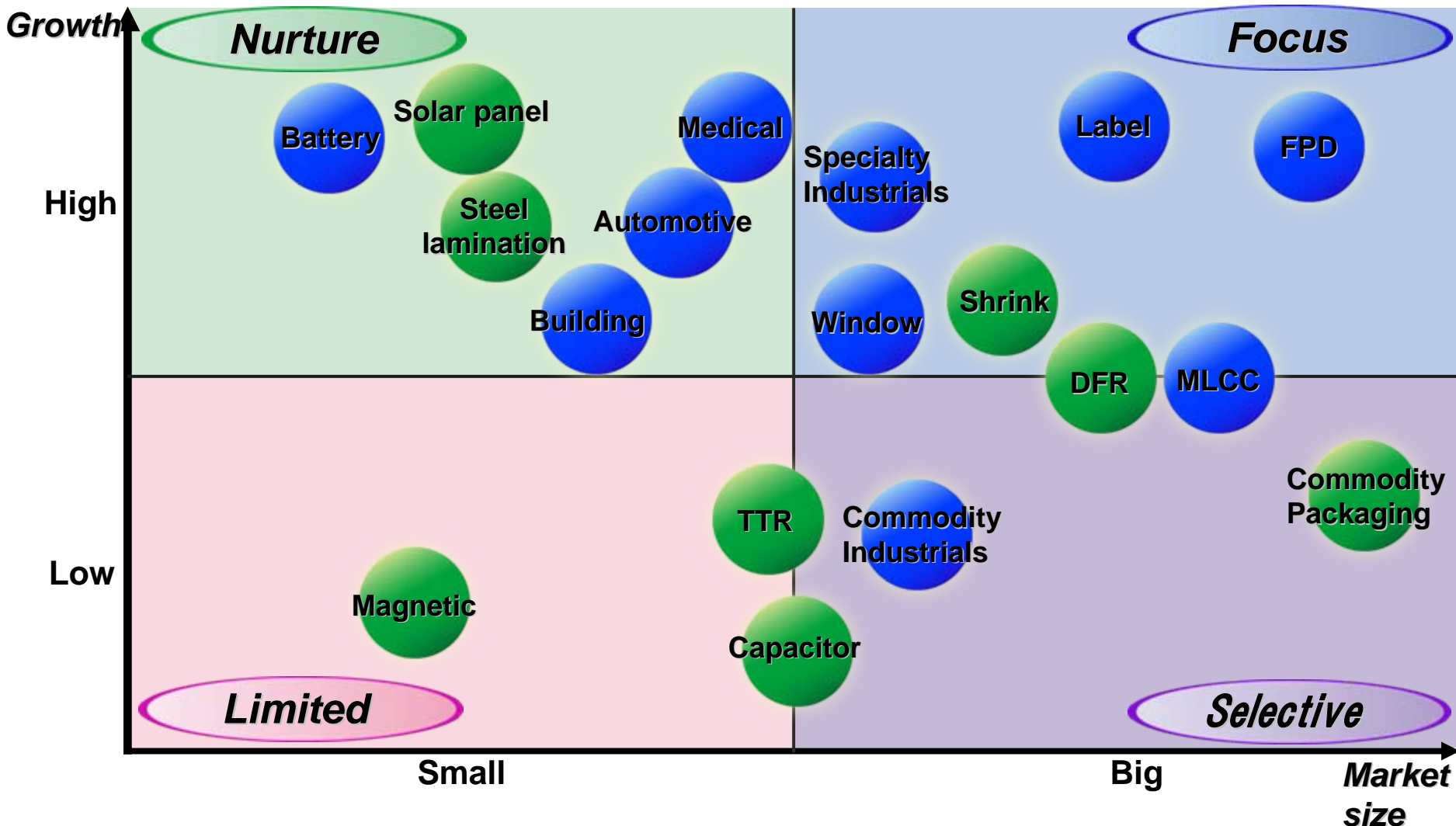

 Release platform technology applied

- Nurture:** Strengthen on product/application development to be No.1 or No.2
- Focus:** Growth strategy with investment
- Limited:** Limited exposure
- Selective:** Selective focus

## What is Release film?

Film with surface property that allows it to separate for functional use as a Carrier/Casting/Protective sheet

### World Class

#### Technology Platform

Resin  
Process  
Coating  
in line / off line  
silicone/ non silicone,  
solvent/solventless/emulsion

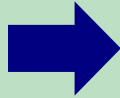

Platforms excellence includes

- Transparency
- Defects free
- Flatness
- Release property

### World Class

#### Customer Collaboration

Long development history  
Investment to meet their needs  
Develop products to make our customers as leaders in the industry

**Wide market applications**

## Success for Release

One fourth of MPF's revenue  
One third of world market share  
Applied key technology in FPD



## By units

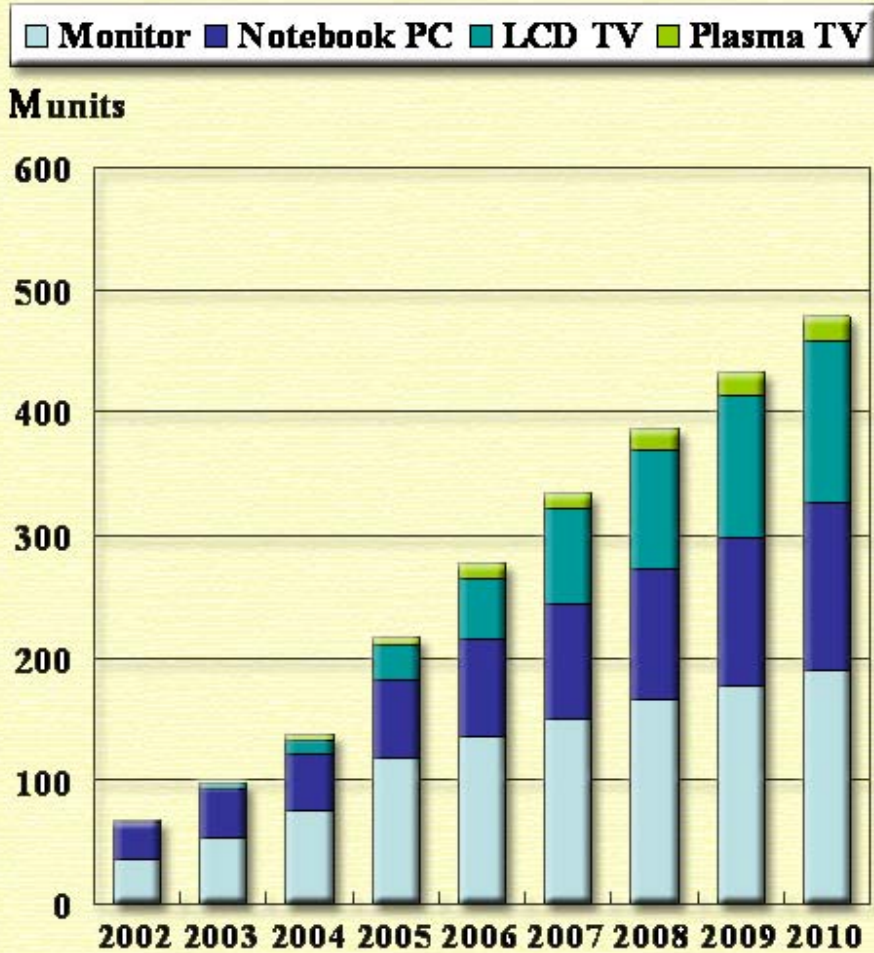

## By areas

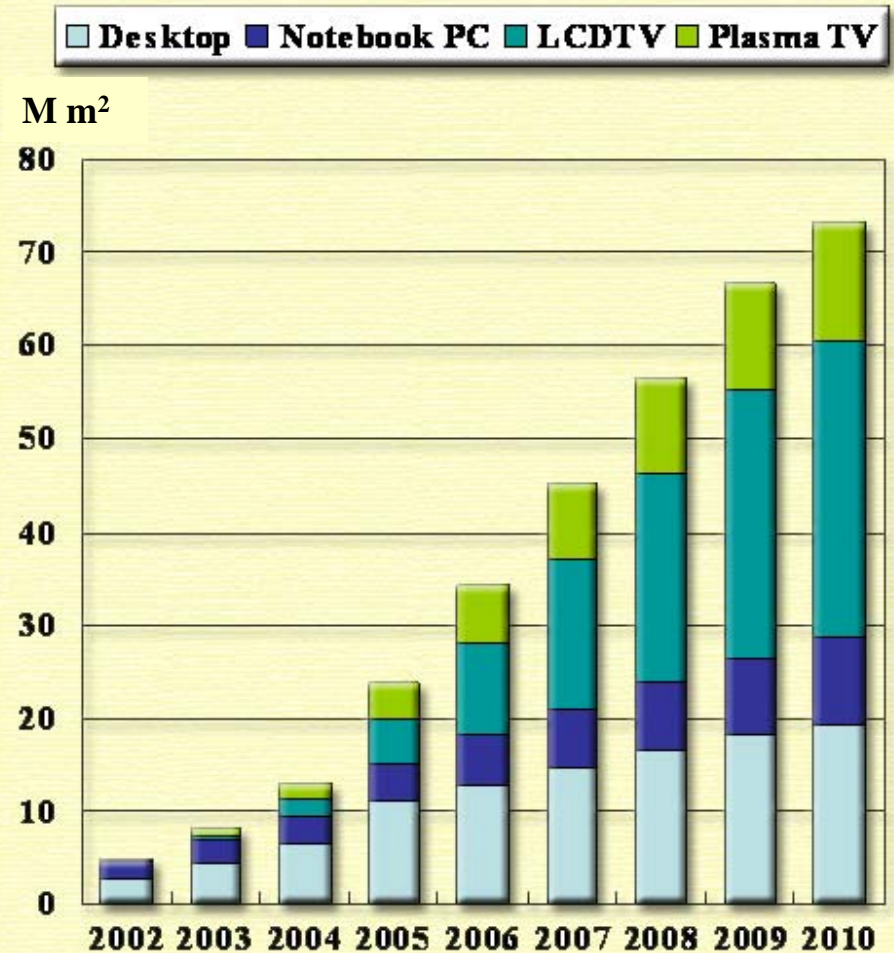

**Leading PET film supplier in FPD**

**Global standard in the industry**

## Wide Market Applications

LCD	Polarizer	PDP	AR
	Release		EMI
	Protective		NIR
	Diffusion sheet		Release
	Prism sheet		
	Reflection sheet		

## World Class Technology Platform

Development of technology platform

- \*Resin
- \*Coating
- \*Manufacturing technology

Synergy with MCC

## World Class Customer Collaboration

Long development history

Investment to meet their needs

Develop products to make our customers as leaders in the industry

# Wide Market Applications - LCD Panel

About 10 pieces of PET film

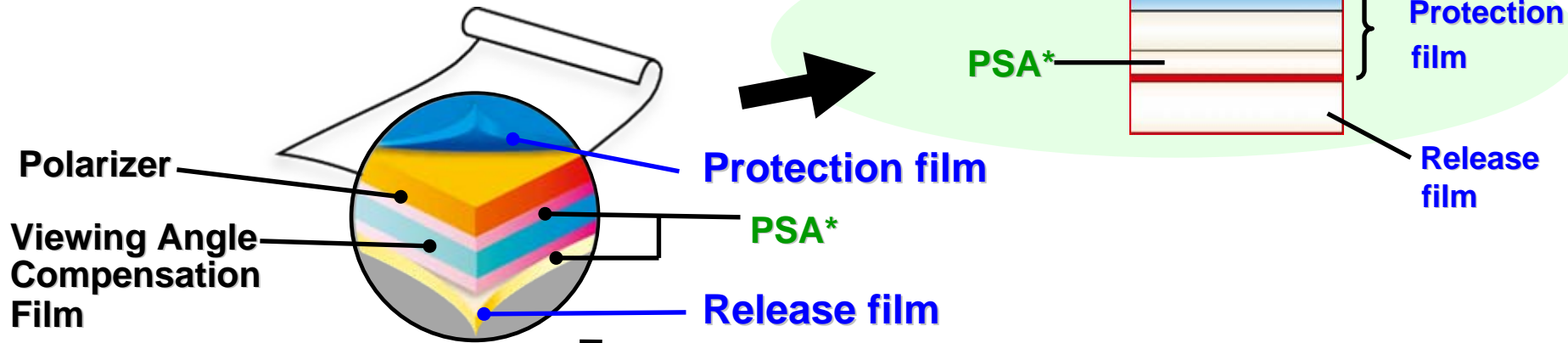

PSA\* : Pressure Sensitive Adhesion

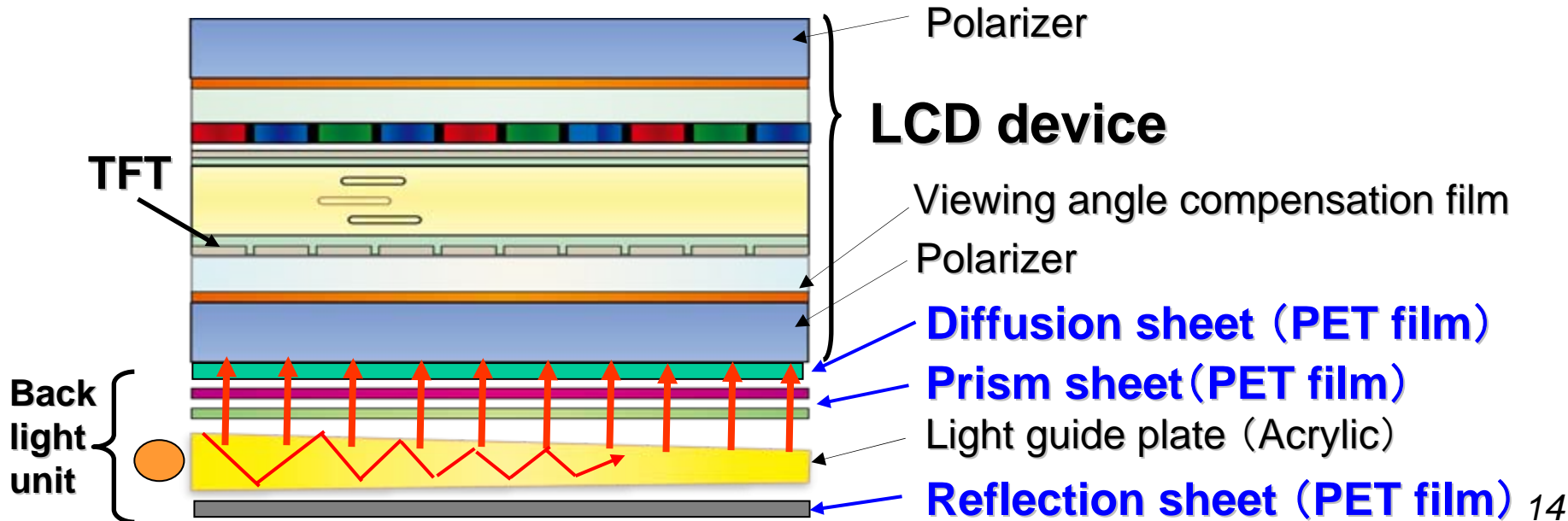



# Wide Market Applications - PDP Panel

## Example of PDP optical filter structure

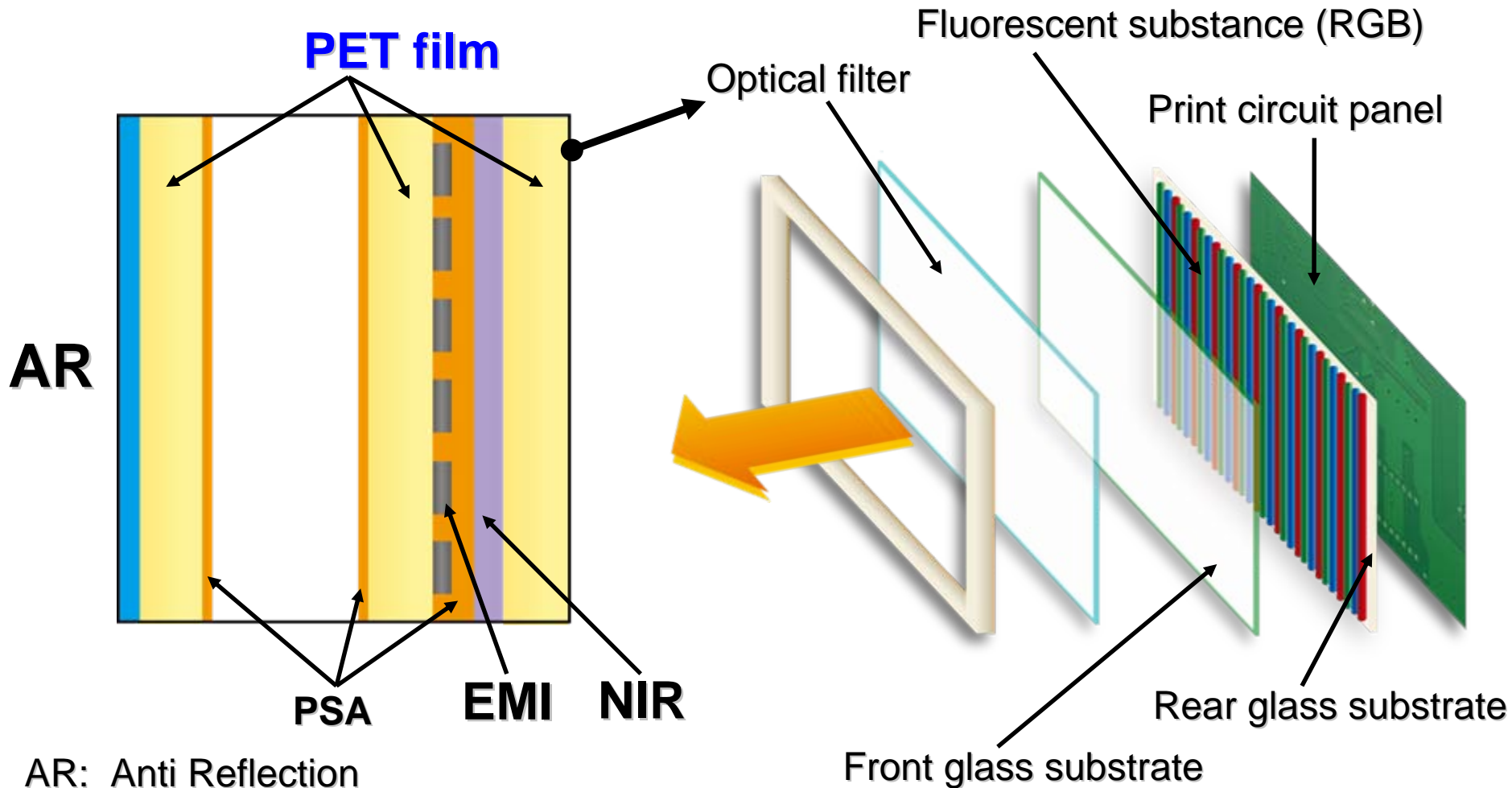

AR: Anti Reflection

EMI: Electro Magnetic Interference

NIR: Near Infrared

**About 5 pieces of PET film** 15

# World Class Technology Platform

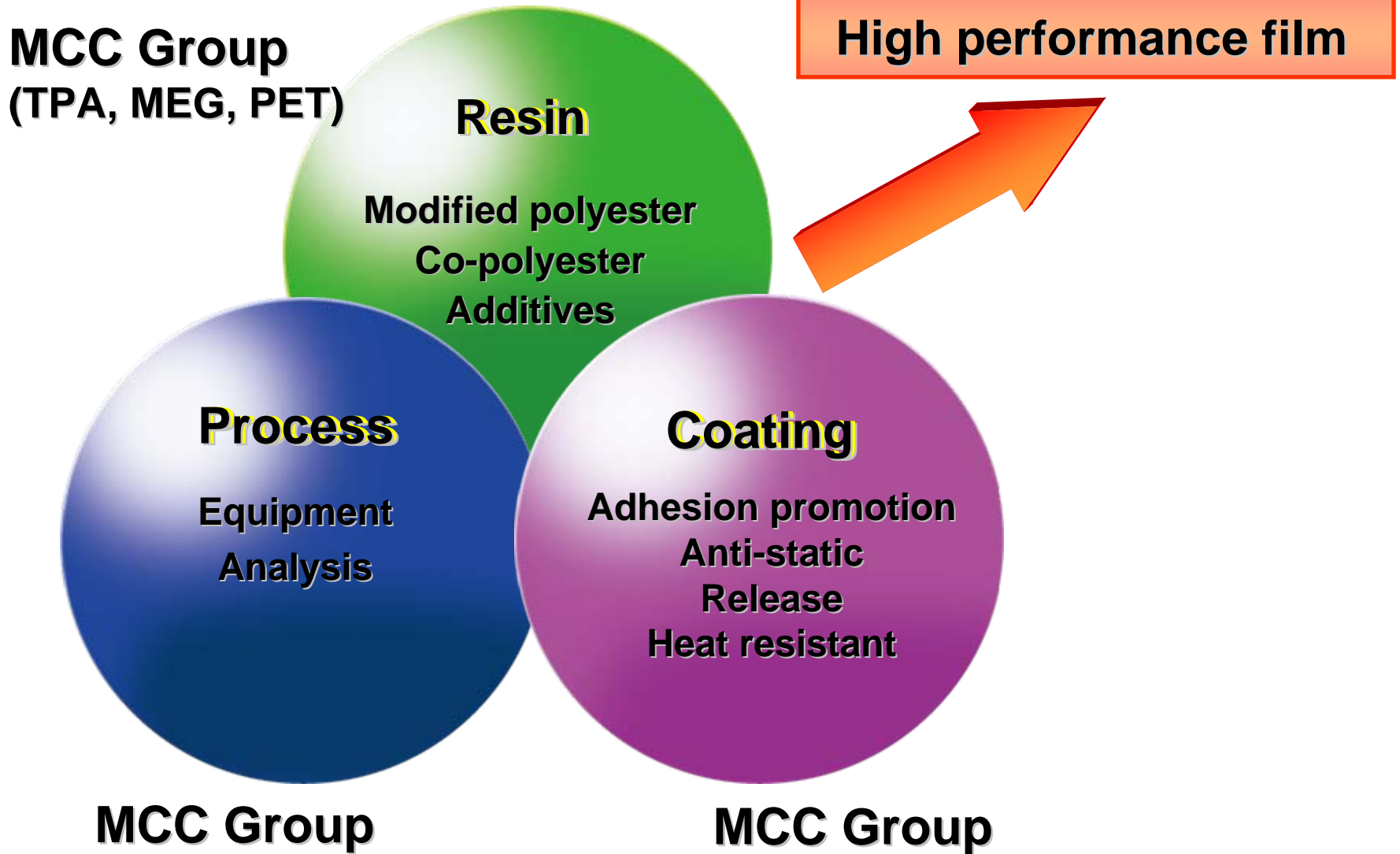

# World Class Customer Collaboration

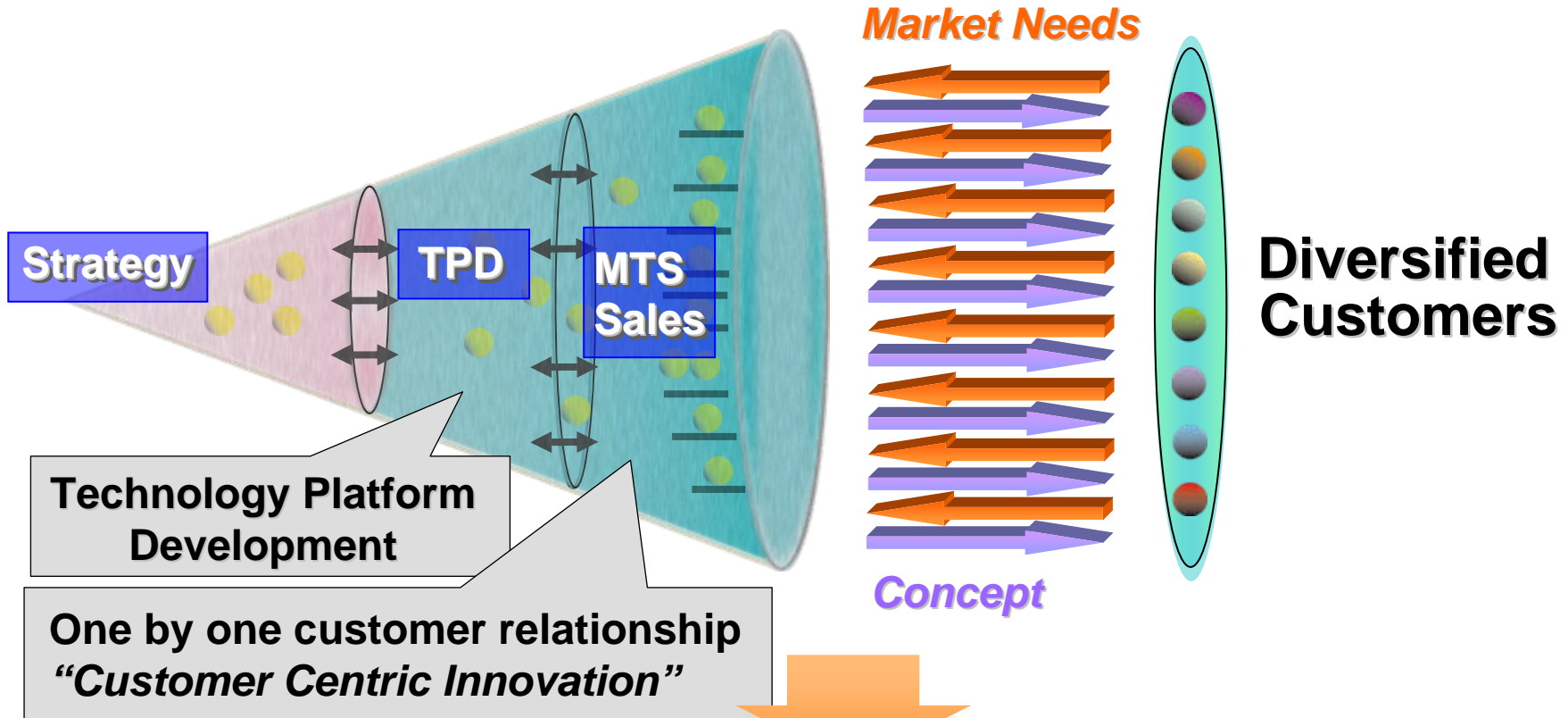

**New products developed for FPD market**

## Results

**Investment**

**High market Share**

**New ideas in development pipe line**

**→ Making our customers as leaders in the industry**

# New Application Opportunities in Future

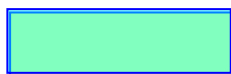
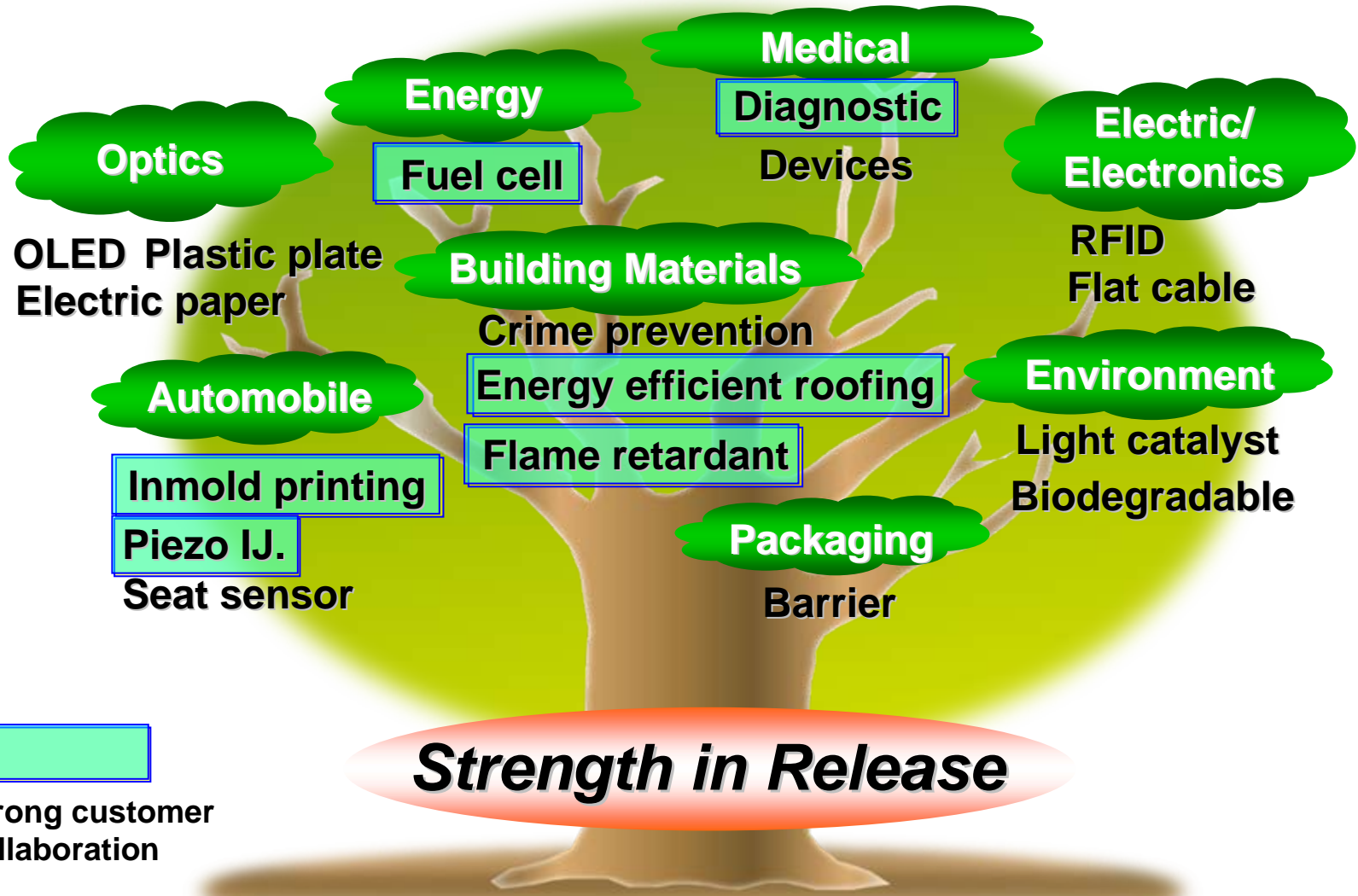

Strong customer collaboration

World Class Technology Platform

World Class Customer Collaboration

## Shareholder Value

Earnings Growth

MPF is committed to invest for growth.

MPF is working jointly with customers to develop products for emerging business opportunities.

MPF is the leading film supplier in FPD due to World Class Technology Platform, Customer Collaboration and Wide Market Applications.

MPF focuses resources based on market valuation with key technology platforms such as release.

MPF's revenue and profitability continue to grow significantly.

MPF is a global company, 100% MCC subsidiary utilizing synergies.

---

▲ Mitsubishi Chemical Functional Products, Inc.

**November 21, 2006**

**Masami Segawa**  
President

# Agenda

---

- **Corporate profile , business overview**
- **Key business ( for IT & Automotive industries )**
- **Expansion plan**
- **2010 Objective**

# MCFP Corporate profile

---

- **Corporate name : Mitsubishi Chemical Functional Products, Inc.**
- **Founded : September 21, 1976**
- **Paid-in capital : 2 billion yen**
- **Employees : 390**
- **Holding company : 100% owned by  
Mitsubishi Chemical Corporation, Inc.**
- **Business division**
  - **Composite Materials Division**
  - **Civil Work Materials Division**
  - **Plastics Pipes & Floor Heating Panels Division**
  - **Functional Chemicals Division**
  - **Logistics Materials Division**
  - **Carbon Fiber & Alumina Fiber Division**
  - **Business Development Division**



# MCFP Business results

**Operating income continuously hit the record for 6 years.  
2006 operating income will be 4 times of 2000.**

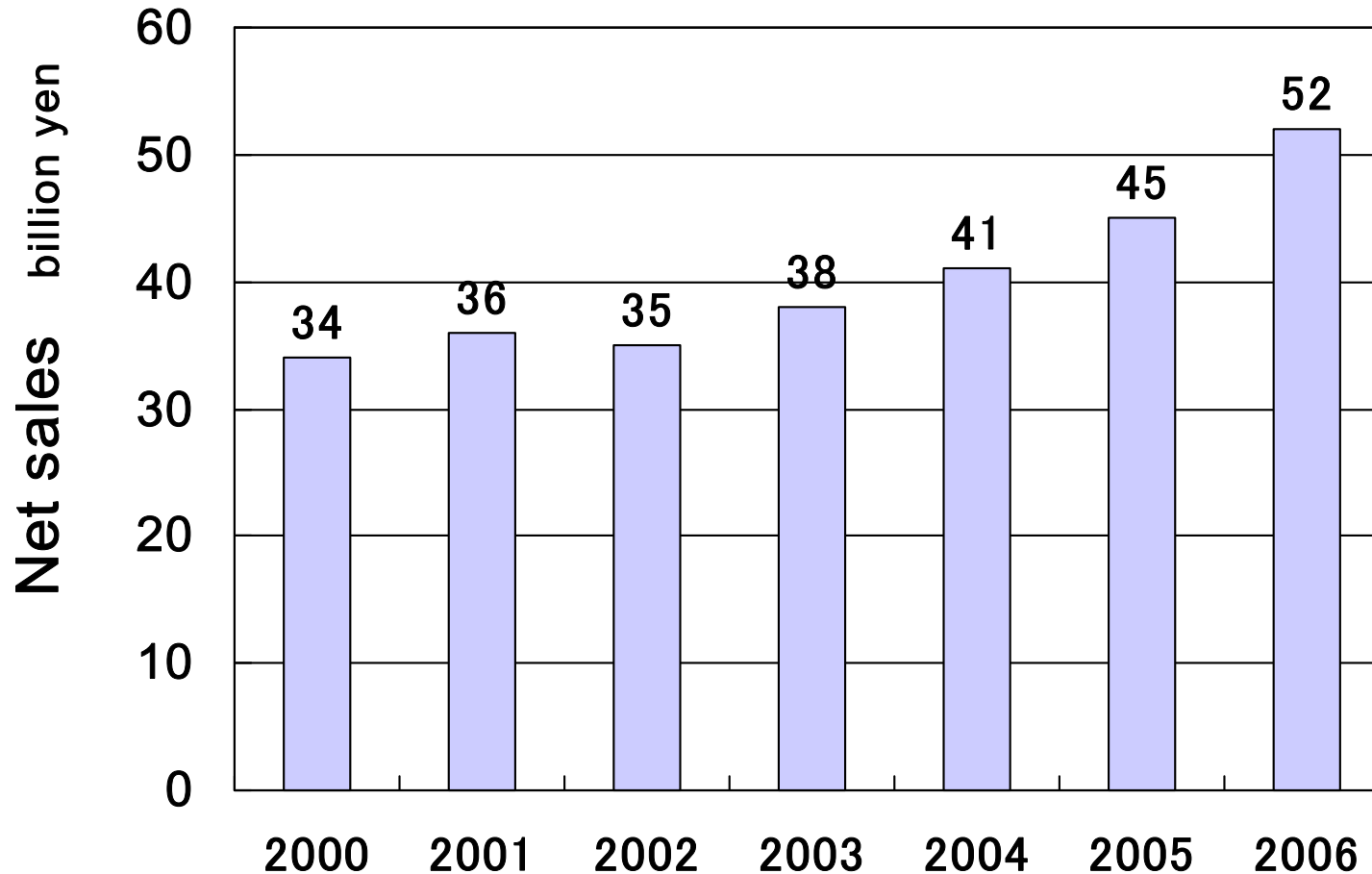

# Sales breakdown

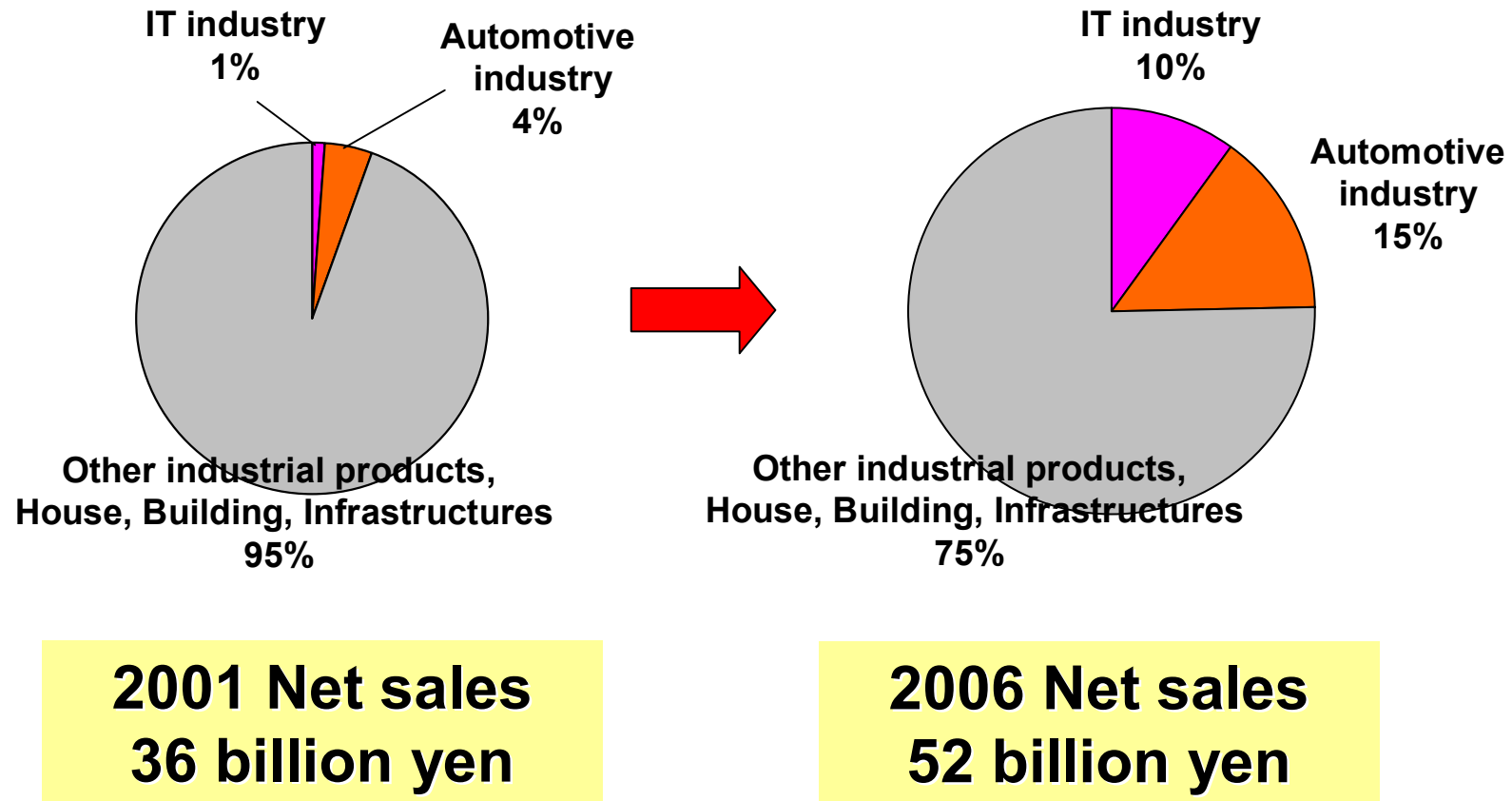

**Expand business in IT & Automotive industries area**

# Introduction of MCFP key business for IT industry

---

# 「DIALEAD」 application in LCD industry

「DIALEAD」: Indispensable to increasing LCD panel size.

**Robot hand**: High speed & stable carry of large size glass panel.

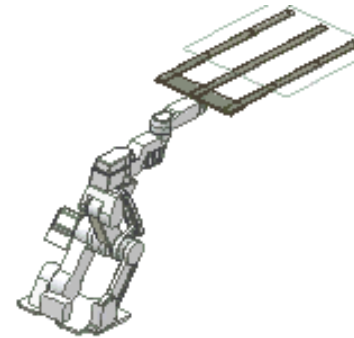
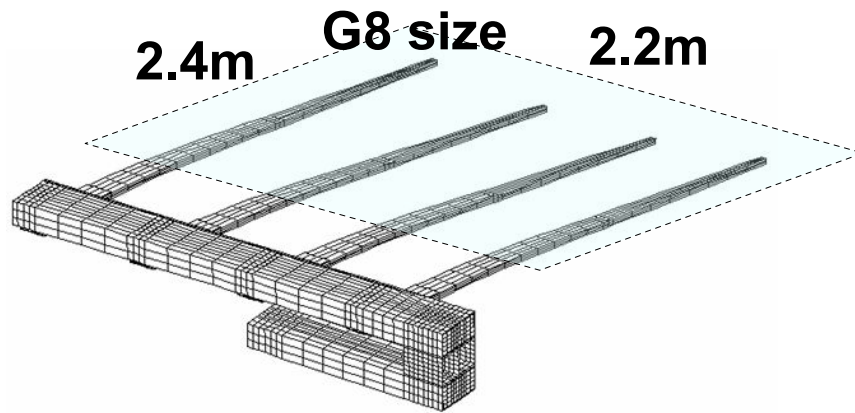

**Low deflection, Quick vibration damping**

- Stable carry
- Reducing tact time

**Roller**: Uniform treatments of glass/film surface. High precision coating.



**Low deflection, Ultra high precise rotation, Low rotational inertia**

- Higher quality by precise movement control
- Higher productivity by high speed production

# CF-robot hand for G9 glass substrates

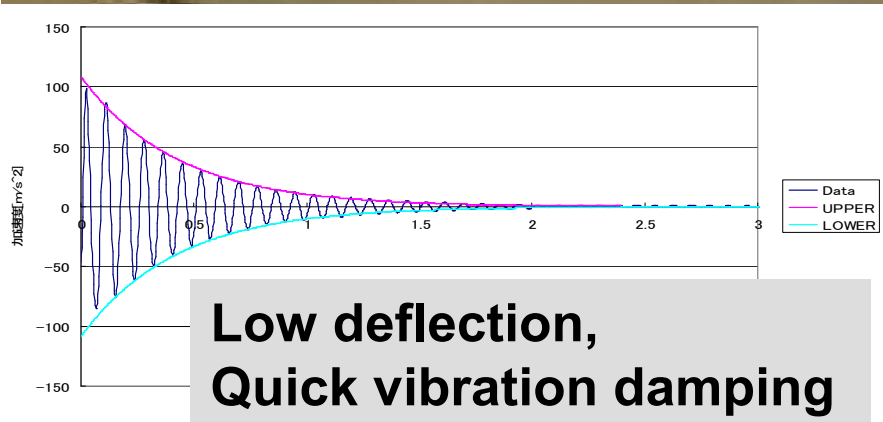



# Application of 「CARBOLEADER」 (CF roller)

LCD film making machine rollers



Coating roller



Rubbing roller

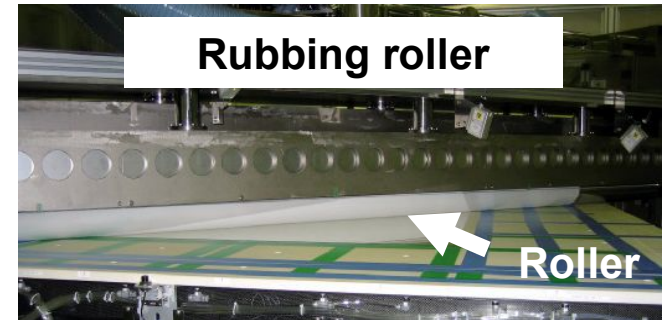

Guide roller of polarizer manufacturing



Guide roller for film splitter (rubber lining)



Winding roller for film splitter



Grooved roller for film splitter

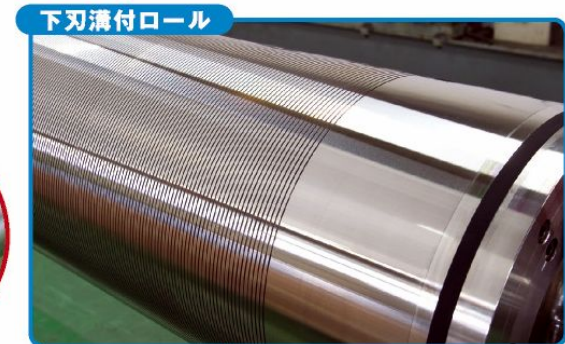

# Advantages of 「CARBOLEADER」

(Light weight, High stiffness, High precision)

**Size:  $\Phi$  140mm  $\times$  3800mmL**

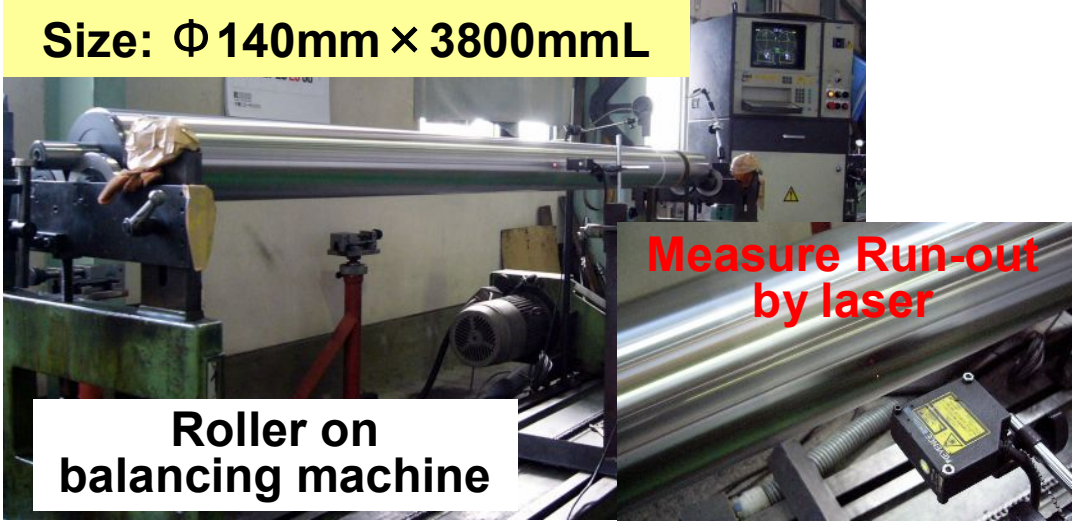

**Measure Run-out by laser**

**Roller on balancing machine**



**RPM and Dynamic balance**



**Run-out: 5micron (0.005mm)**

## Data of each materials performance

Material	OD [mm]	ID [mm]	Face [mm]	Weight [kg]	Deflection [mm]	Moment of inatia [kg·m <sup>2</sup> ]	Critical speed [m/min]
Steel	260	235	5,000	506	<0.1	26.7	1,450
Aluminum	280	245		250		14.8	1,520
Carbon	180	156		106		2.7	2,080



# Use of 「CARBOLEADER」 on LCD-parts production (Underlined)

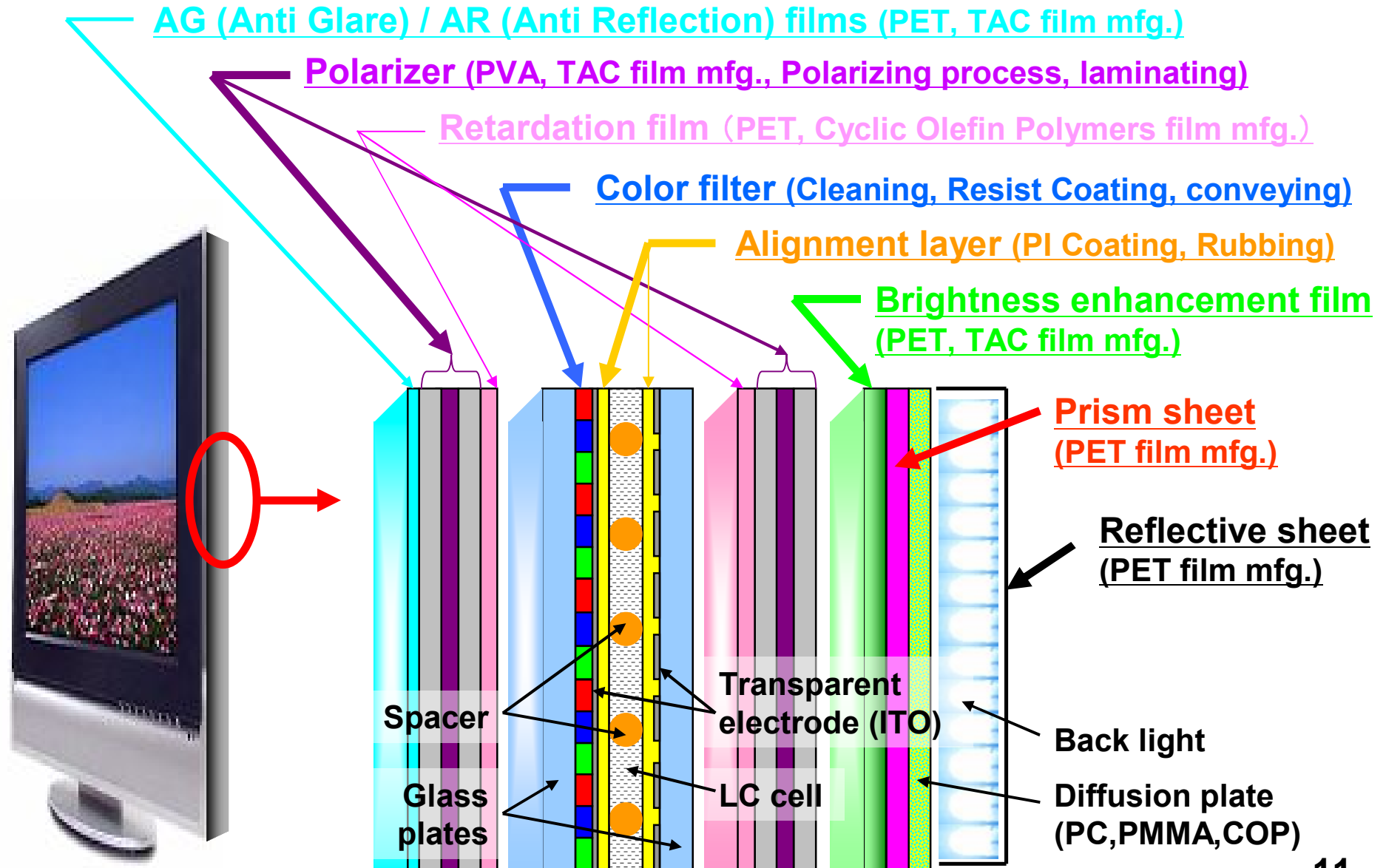



# For film manufacturing line

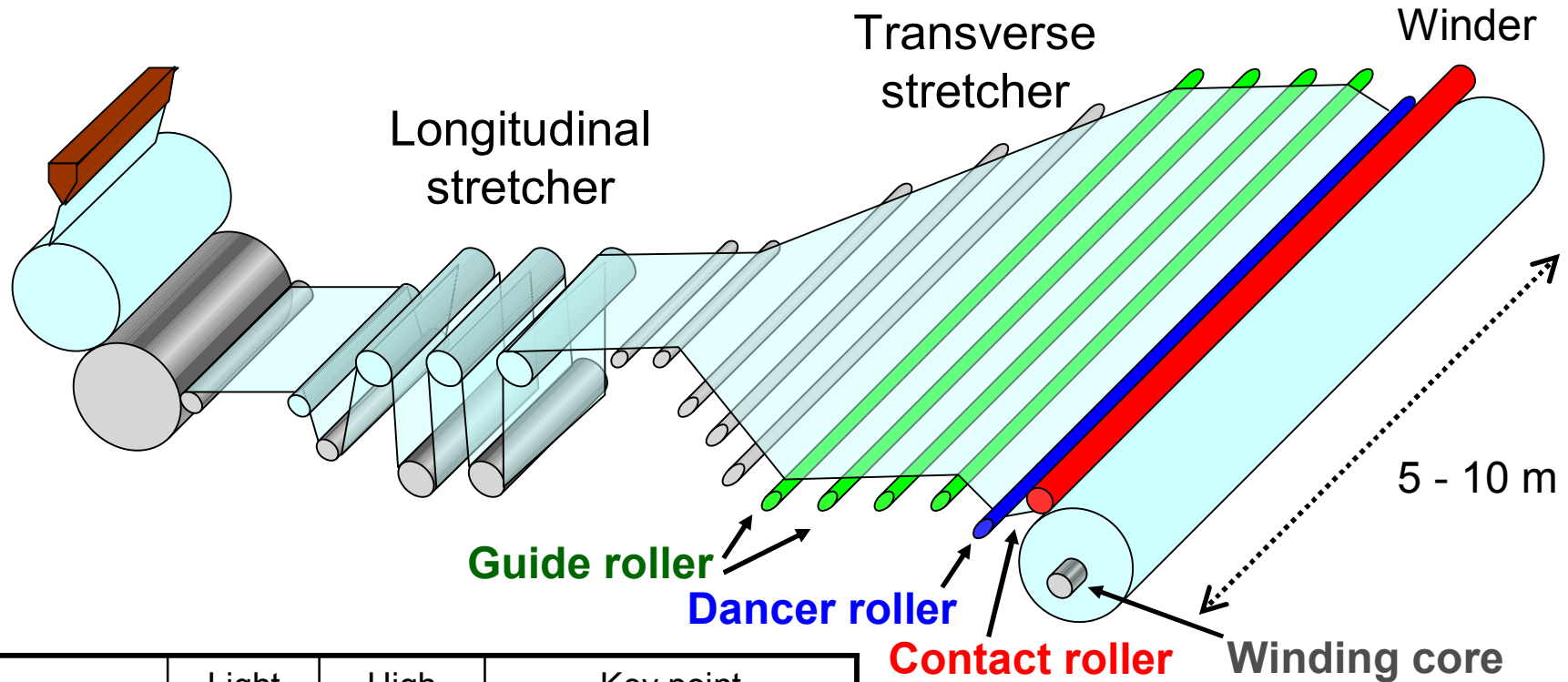

	Light Weight	High stiffness	Key point
Guide roller	○	○	Higher speed
Dancer roller	○		Sensitive controlability
Contact roller		○	Quality improvement
Winding core	○	○	Quality improvement

**Big advantages at transverse stretch process of film making**

- Low deflection
- High speed & stable rotation
- Low inertia

# Demand forecast of LCD panel (Substrate)

Rapid growth of TV application

\*by MCFP estimates

: Expand capacity up to 150-200 million m<sup>2</sup>/year

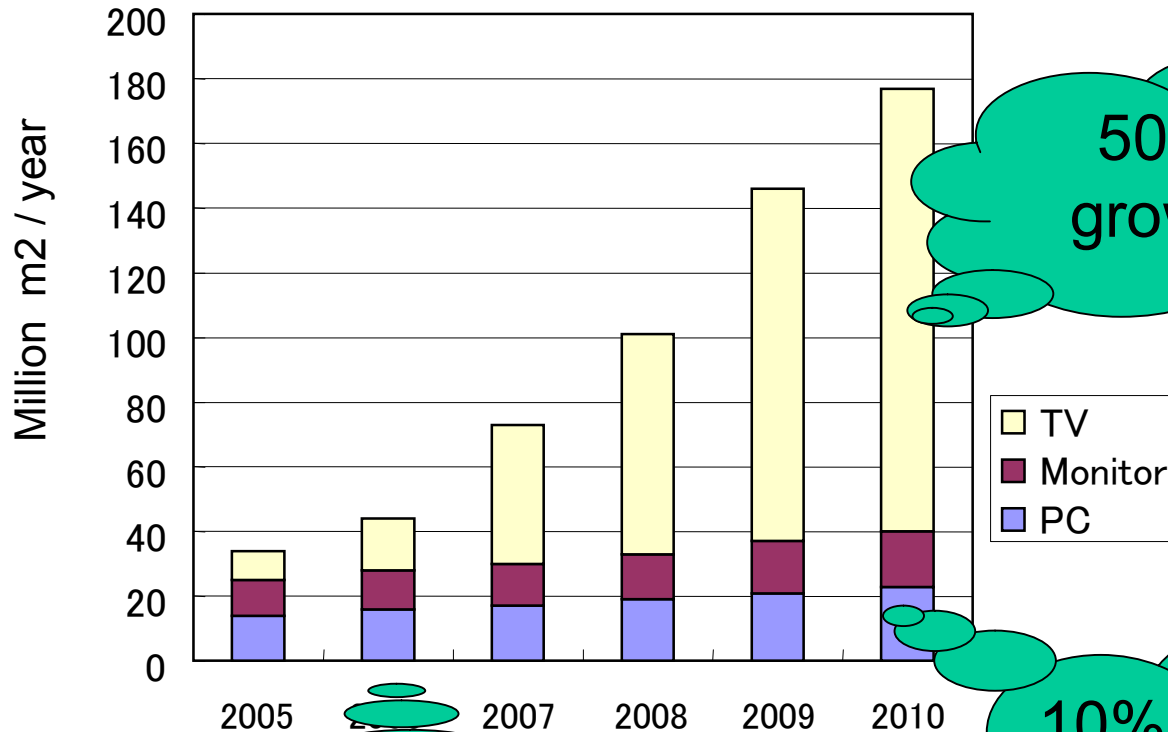

50% / year growth in TV

10% / year growth in PC & Monitor

LCD panel capacity  
44 million m<sup>2</sup>/ year in 2006

# Sales forecast of robot hand & rollers

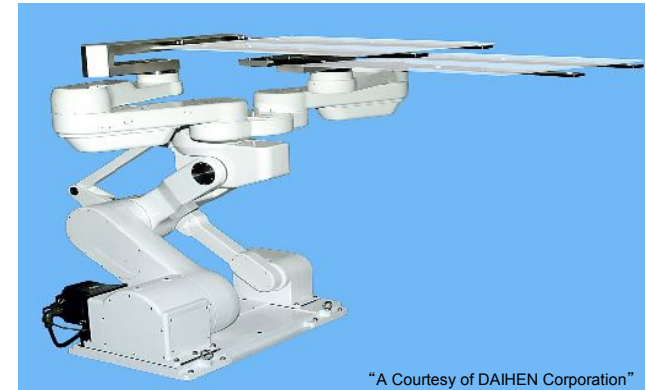
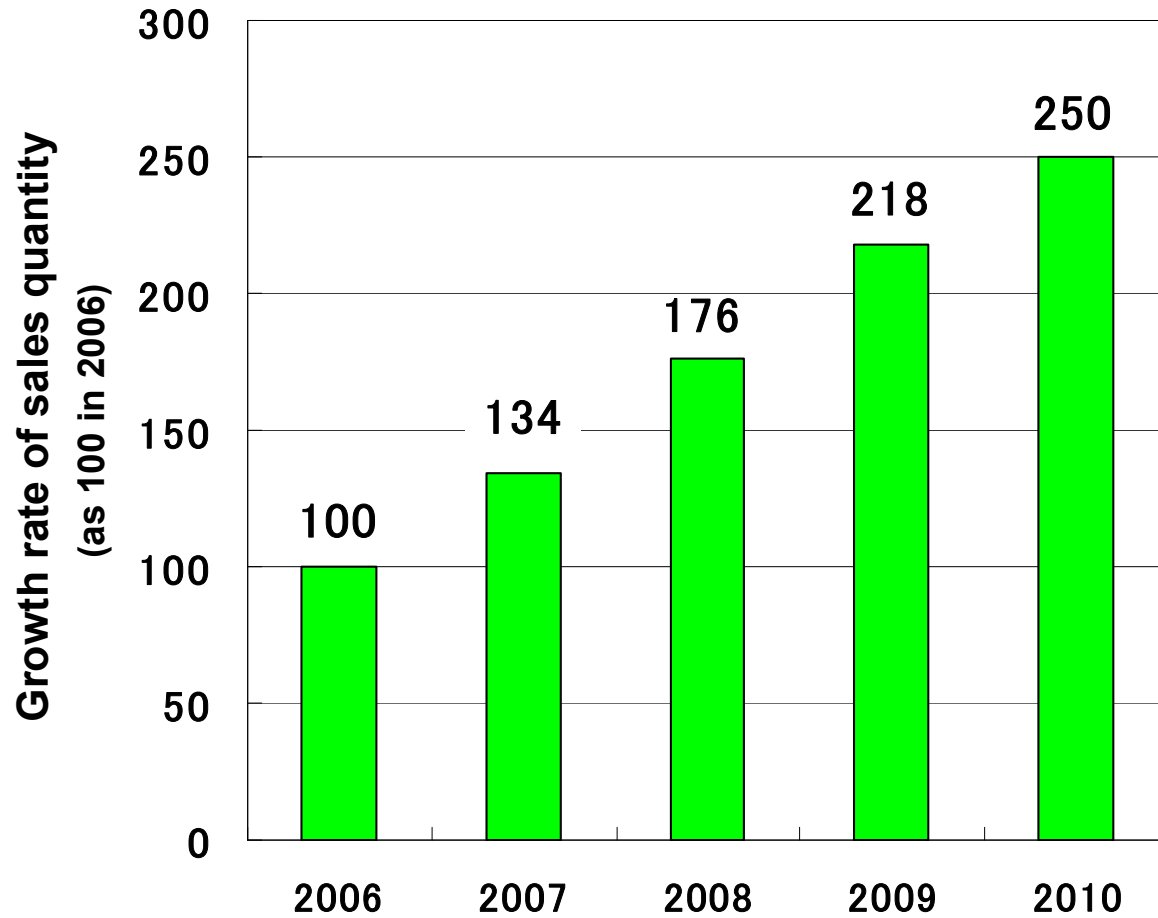

# Introduction of MCFP key business for Automotive industry

---

# Carbon brake

- **Light weight** : Density ratio 1/3 ( carbon 1.9 , cast iron 7.9 )  
Weight reduction 24kg / car ( cast iron 9kg , carbon 3kg, 4 discs)
- **Heat resistance** : Excellent friction and safety at high speed driving
- \* **Ceramic brake**  
Improvements in friction and wear resistance by ceramic for high performance motorcycle and automobile

## Carbon brake for Motorcycle



## Ceramic brake

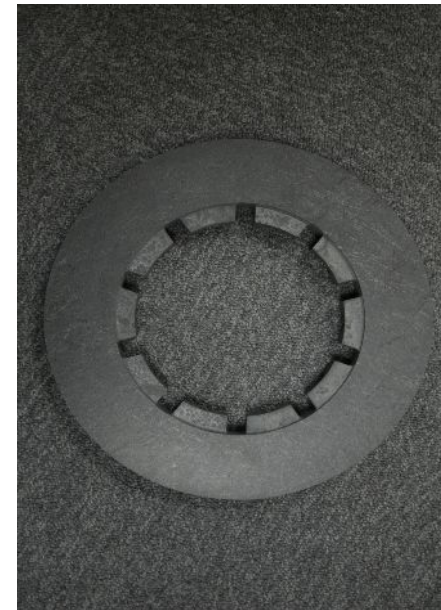

# World emission controls push alumina fiber demand

- CO2 concerns promote diesel engines
- Rising fuel prices accelerate shifting to diesel/hybrids (gasoline, diesel)

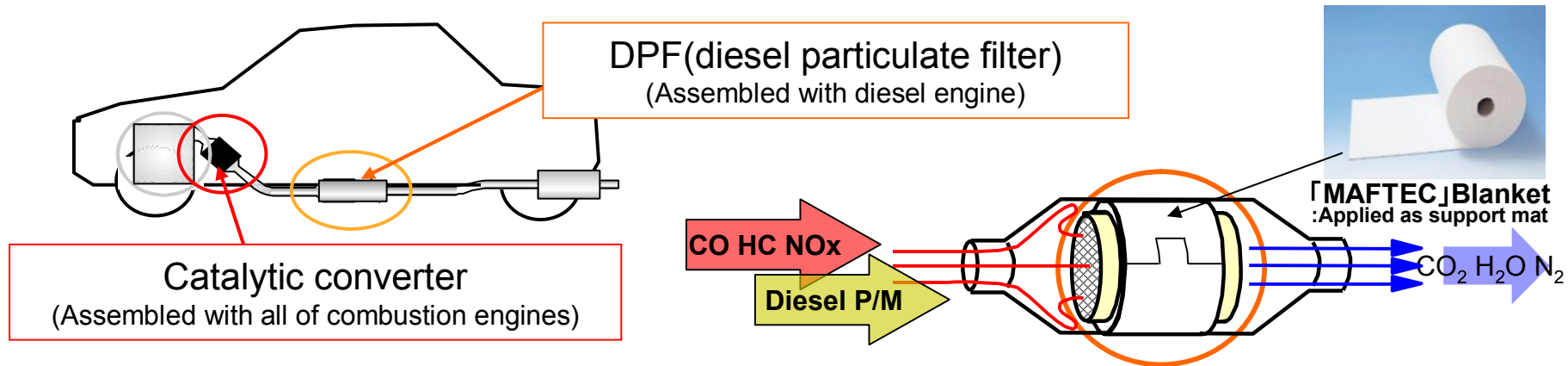

## World emission controls

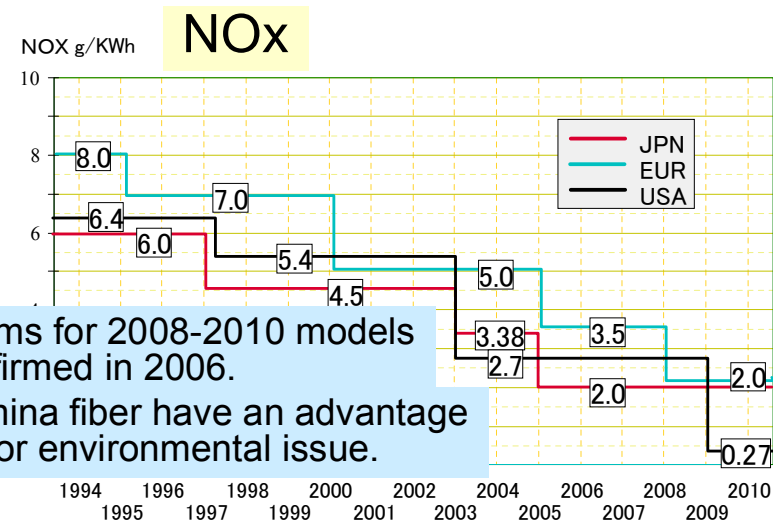
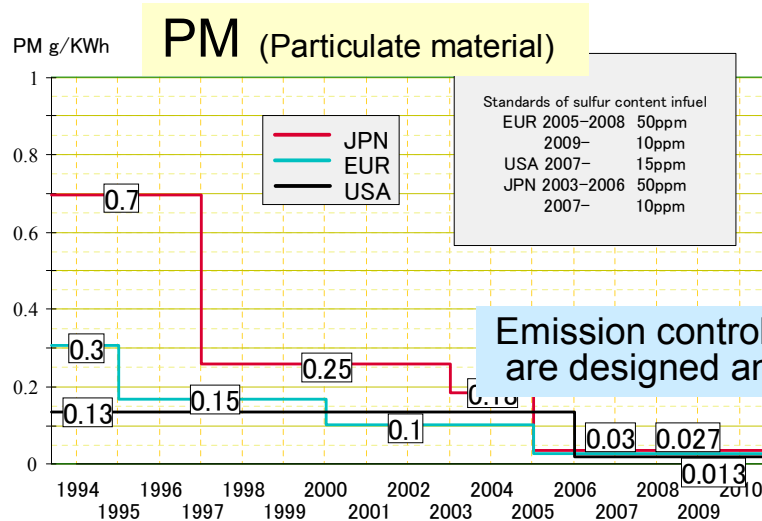

Emission control systems for 2008-2010 models are designed and confirmed in 2006.

Alumina fiber have an advantage as for environmental issue.

# Demand forecast of support mat application

\*by MCFP's estimate

## World automotive productions

(including trucks and buses)

Million/year

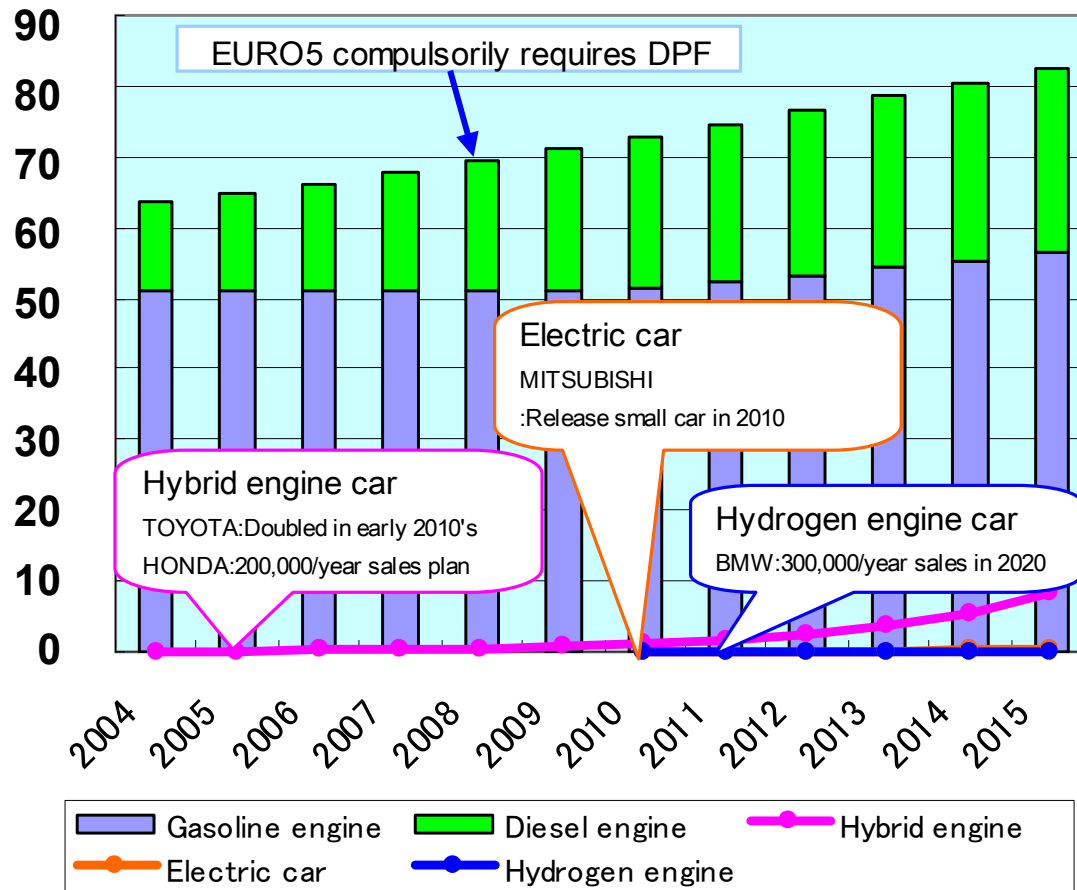

ton/year

## Alumina fiber for support mat

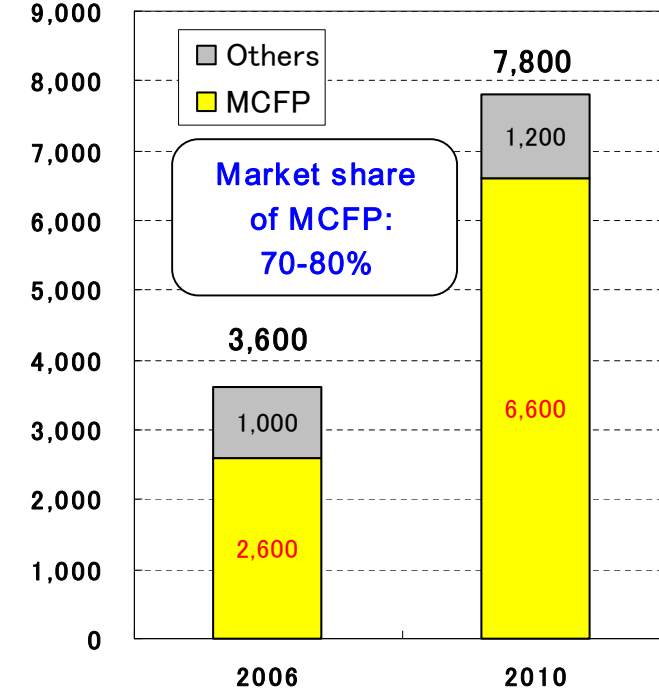



# Demand forecast of DPF support mat application (Passenger cars)

## Registered diesel passenger cars ( Thousand/year )

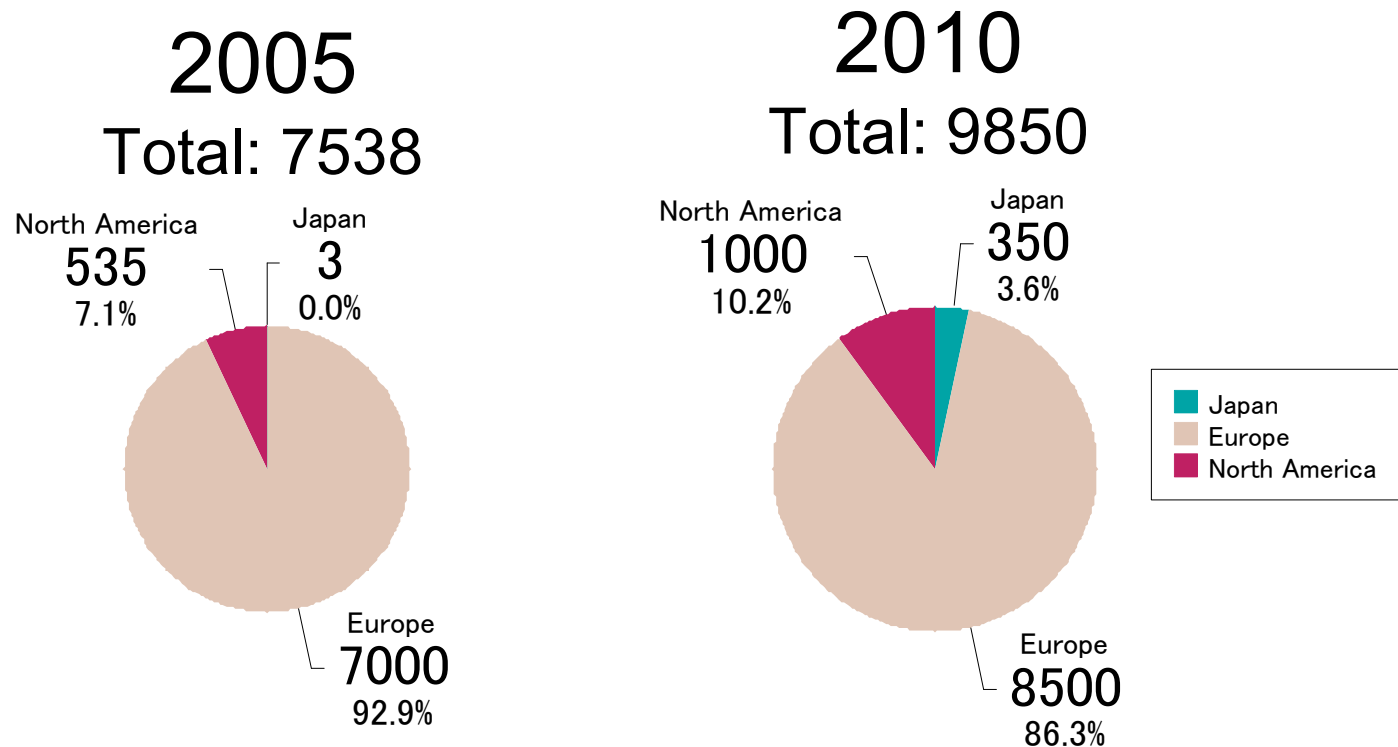

**Cars : 2.3 million increase in 5 years.**

**Alumina fiber : 1,200 ton increase in 5 years, Total demand in 2010 is ca.5,000 ton.  
( 0.5kg/car is used )**



# Expansion plan

---

# Carbon fiber 「DIALEAD」 expansion plan

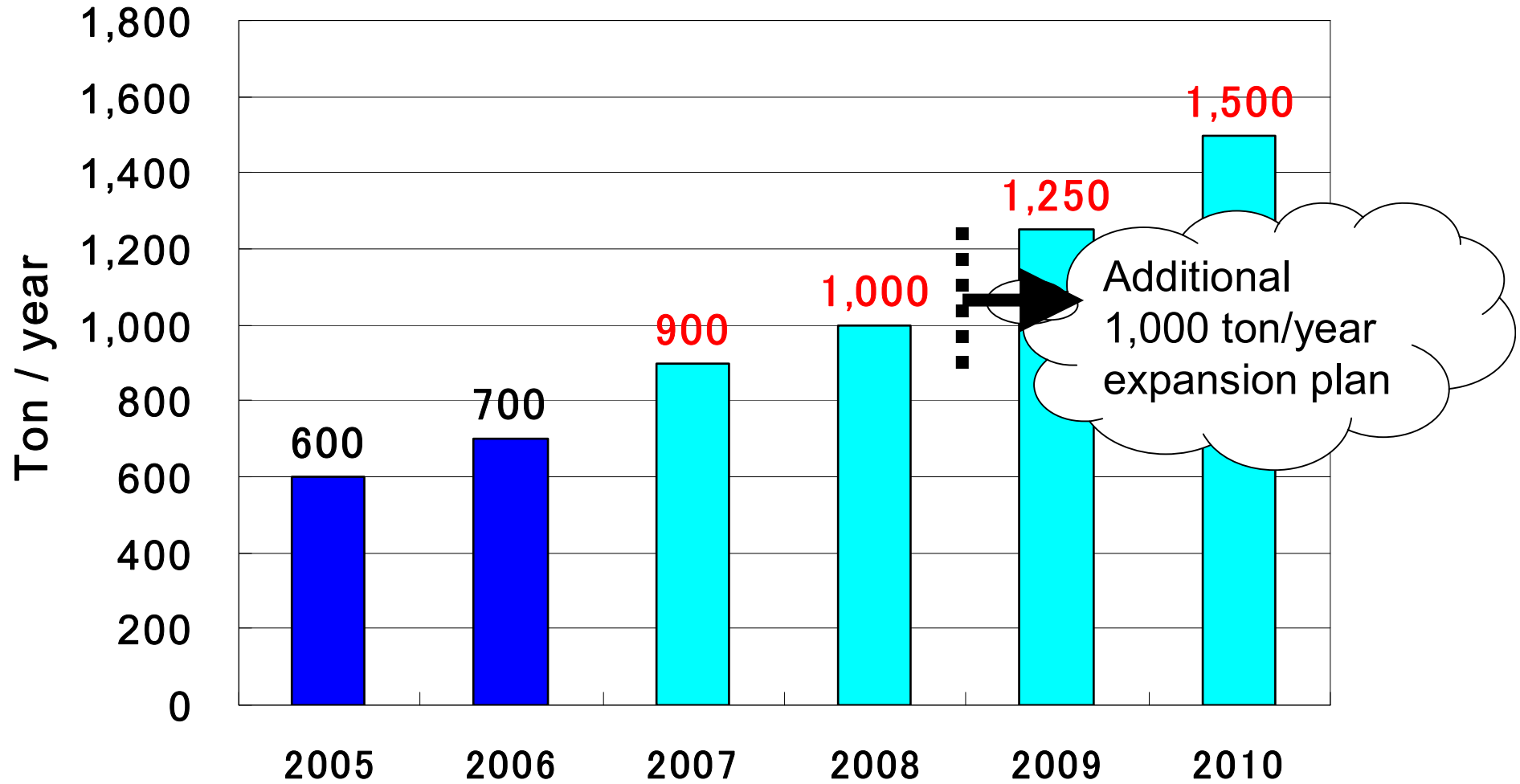

# Carbon fiber applications and demand (outlook)

Tensile Strength [GPa]      2008    33,000ton (Pitch-CF 1,200ton)  
(O : Market scale image)

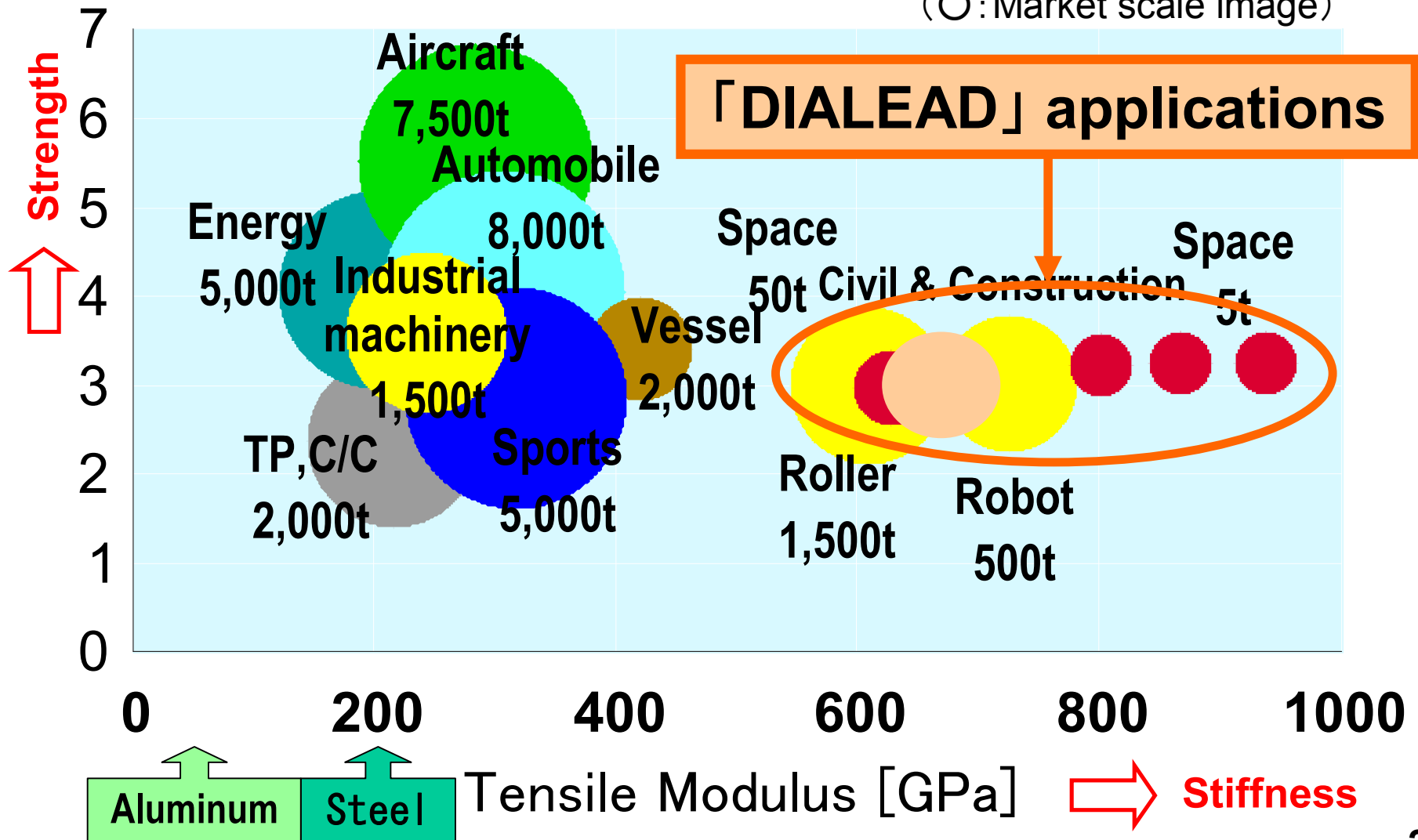

# Alumina fiber 「MAFTEC」 expansion plan

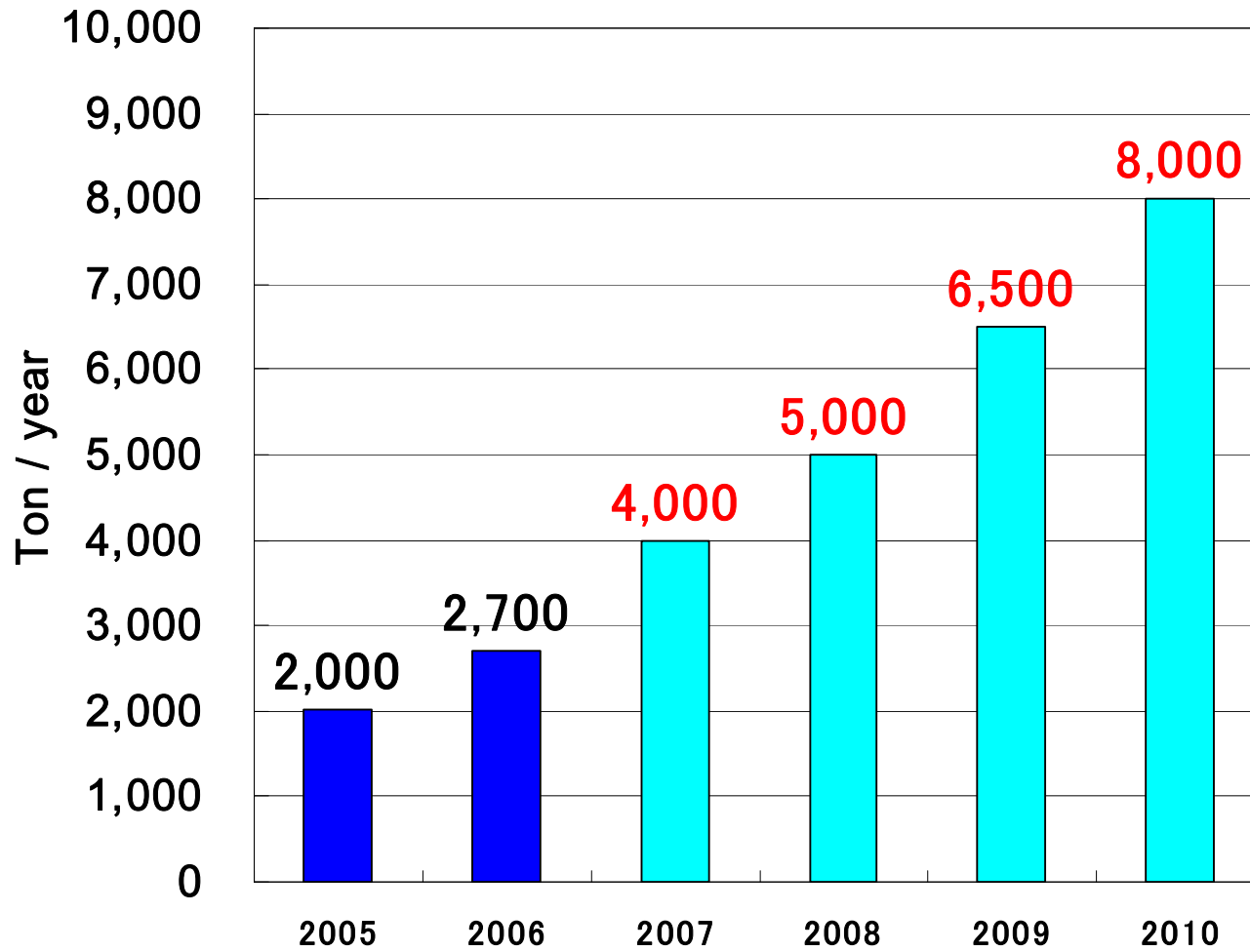

## Alumina fiber Market volume & share (Estimation)

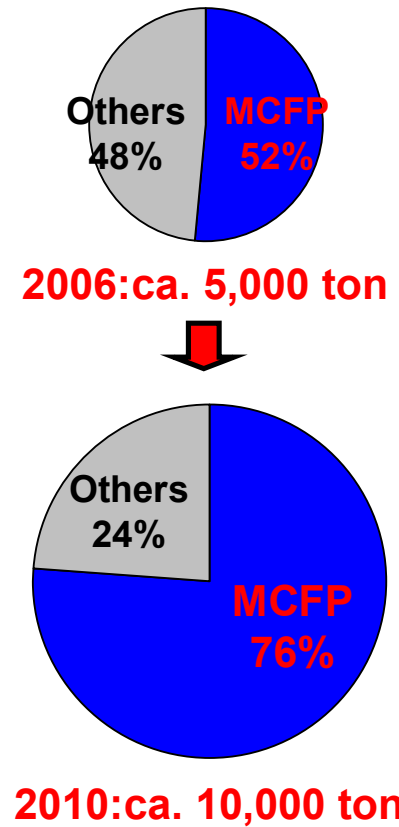

# MCFP Sakaide plant

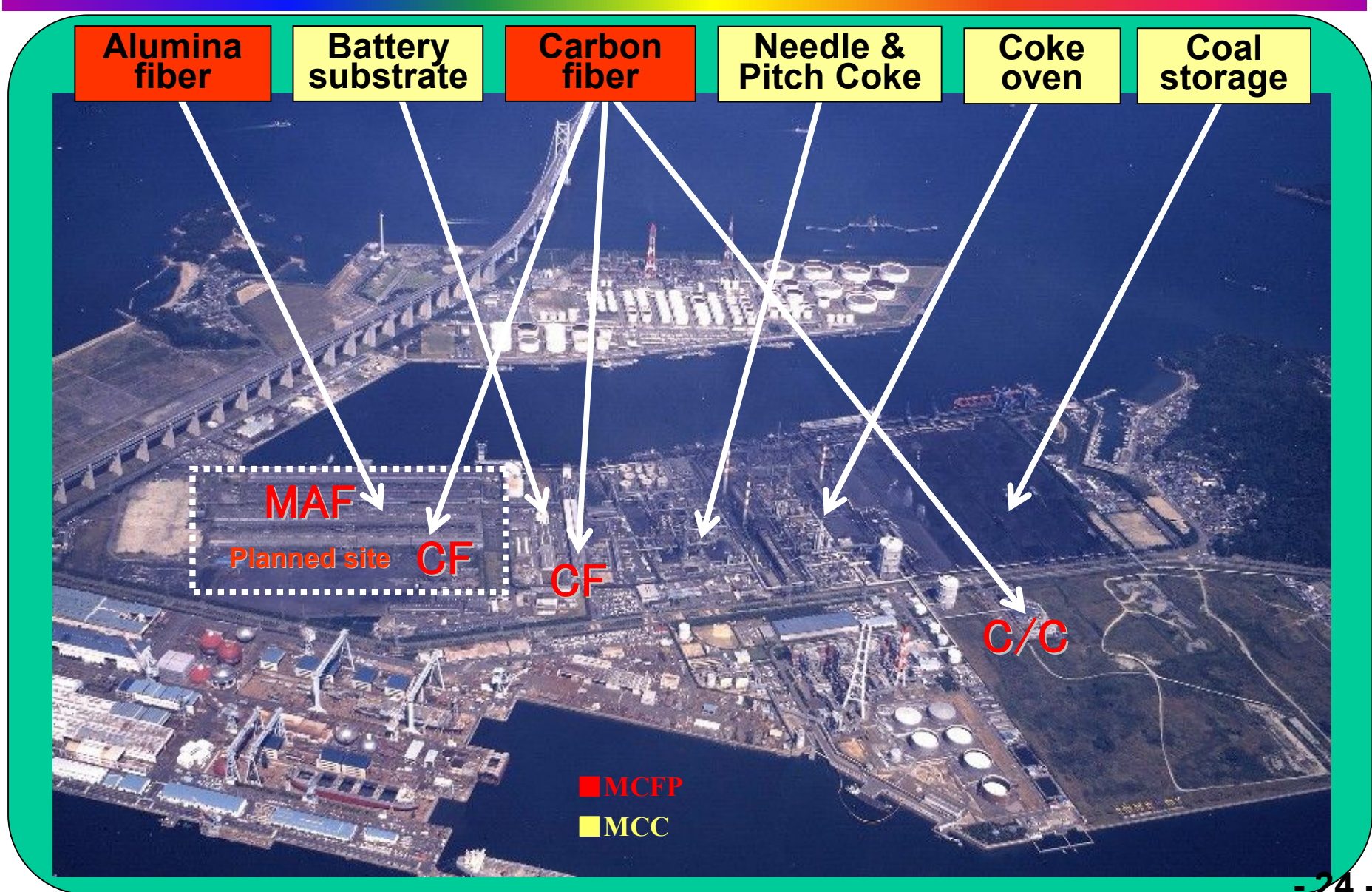

# 2010 Objective

---

# MCFP 2010 Objective

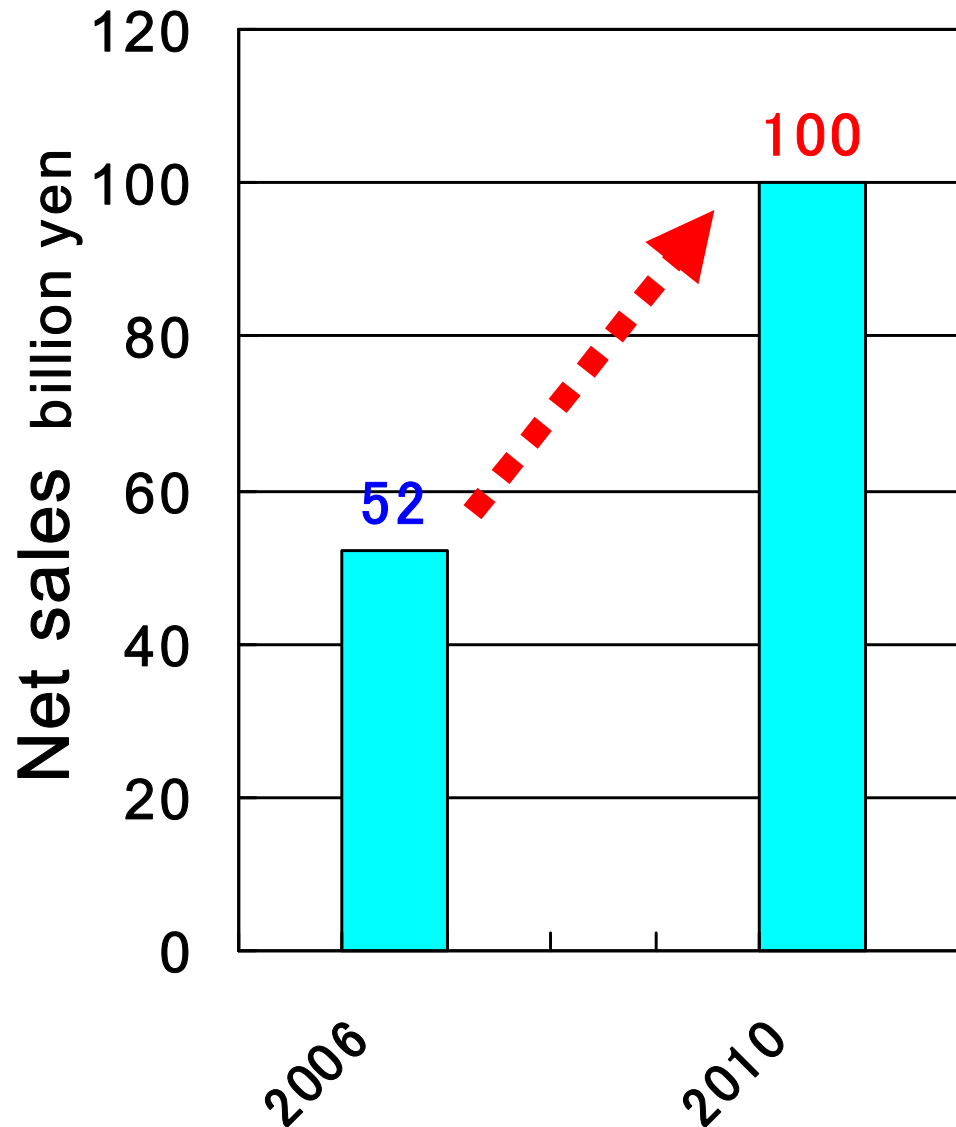

## 2010 Objective !

- ✓ **Continuous growth**  
10 years continuous growth
- ✓ **Net sales: 100 billion yen**
- ✓ **Operating income**  
: 10 billion yen
- ✓ **ROA: Over 15%**
- ✓ **ROS: Over 10%**
- ✓ **Investment**  
: About 10 billion yen/year



## Forward-looking Statements

The forward-looking statements are based largely on information available as of the date hereof, and are subject to risks and uncertainties which may be beyond company control. Actual results could differ largely, due to numerous factors, including but not limited to the following: Group companies execute businesses in many different fields, such as petrochemicals, carbon and inorganic products, information and electronics, pharmaceuticals, polymers and processed products, and these business results are subjected to influences of world demands, exchange rates, price and procurement volume of crude oil and naphtha, trend of market price, speed in technology innovation, National Health Insurance price revision, product liabilities, lawsuits, laws and regulations.